

**BEFORE NATIONAL GREEN TRIBUNAL, PRINCIPAL BENCH, NEW  
DELHI**

**ORIGINAL APPLICATION NO.53 of 2024**

**IN THE MATTER OF**

FARHA KHAN

.....APPLICANT

Versus

STATE OF UTTAR PRADESH and ORS

.....REPOONDENTS

**INDEX**

SL. NO.	PARTICULAR	ANNEXURE	PAGE NO.
1.	Second Reply on behalf of Respondent No.4 alongwith affidavit.		1-9
2.	Copy of Letter of Acceptance dated 5 <sup>th</sup> November 2018	Annexure A1	10-12
3.	Copy of Challan dated 29.08.2024 alongwith letter dated 2.9.2024	Annexure A2	13-14
4.	Copy of Notification dated 10.09.2024	Annexure A3	15-16
5.	The photographs of all compost pits	Annexure A4	17-20
6.	The photographs of these composters placed at banquet halls	Annexure A5	21-25
7.	Copy of Detailed Project Report regarding construction of Compost Plant	Annexure A6	26-41
8.	Copy of the agreement dated 20 <sup>th</sup> April 2023 for consuming RDF	Annexure A7	42-44

9.	Copy of photograph of Premपुरी / Thana Bhawan Road	Annexure A8	45
10.	Copy of Photographs of Nayi Mandi Gate No.3	Annexure A9	46
11.	Latest photograph of the site i.e Ladhawala site	Annexure A10	47
12.	Copy of e-tender dated 5.10.2023	Annexure A11	48
13.	Copy of letter dated 9.6.2024	Annexure A12	49
14.	Copy of Board Resolution dated 20.7.2024	Annexure A13	50
15.	Copy of letter dated 13 <sup>th</sup> June 2024	Annexure A14	51-55
16.	Copy of e-tender dated 22.6.2024 alongwith report	Annexure A15	56-57
17.	Copy of e-tender dated 30.07.2024	Annexure A16	58
18.	Copy of e-tender dated 10.09.2024	Annexure A17	59

**RAUNAK PAREKH**  
Advocate

Mobile: 9919024666  
Email ID: raupar1986@gmail.com  
Reg. No: UP/117/11

*RParekh*

**RAUNAK PAREKH**  
COUNSEL FOR THE RESPONDENT NO.4  
Basement No.2, Block B3,  
Manu Apartment, Mayur Vihar-1, Delhi-91  
ENROLLMENT NO.:- UP/117/2011  
PH. NO. 9919024666  
Email: raupar1986@gmail.com

**BEFORE NATIONAL GREEN TRIBUNAL, PRINCIPAL BENCH, NEW  
DELHI**

**ORIGINAL APPLICATION NO.53 of 2024**

**IN THE MATTER OF**

FARHA KHAN

.....APPLICANT

Versus

STATE OF UTTAR PRADESH and ORS

.....REPOENDENTS

**REPLY ON BEHALF OF NAGAR PALIKA PARISHAD  
MUZAFFARNAGAR (RESPONDENT NO.4)**

**MOST RESPECTFULLY SHOWETH:**

1. That this is the Second Reply which is being filed on behalf on Nagar Palika Parishad Muzaffarnagar, (Respondent No.4).
2. That the present Executive Officer, Nagar Palika Parishad apologises before this Hon'ble Court and seeks mercy of this Hon'ble National Green Tribunal. It is submitted that the intention of Nagar Palika Parishad was not to mislead this Hon'ble Court. The statement mentioned in the report regarding pending of "some legacy waste" is a mistake and is highly regretted the Executive Officer submits her unconditional apology for mentioning the that "some quantity of legacy waste still remains at the dump site".

3. That the Hon'ble National Green Tribunal was pleased to pass an order dated 23.9.2024. Certain deficiencies were pointed out by the Hon'ble National Green Tribunal. The point-wise explanation is mentioned below:-

- i. It is submitted that State Government of Uttar Pradesh has entered into an agreement with GC International directly surpassing the role of Nagar Palika Parishad and the said Action Plan was submitted by GC International. This fact is apparent from letter of acceptance dated 5<sup>th</sup> November 2018, which is annexed as Annexure A4 in the previous report dated 26<sup>th</sup> June 2024, and is again annexed in this report as **ANNEXURE -A1**.

It is necessary to point out that Nagar Palika Muzaffarnagar was ordered to provide land to GC International. In compliance of the order / instructions received from Government of Uttar Pradesh, Nagar Palika Parishad provided land to GC International for construction through lease deed dated 19<sup>th</sup> Oct 2023.

In compliance of the order / directions of Government of Uttar Pradesh, Nagar Palika Parishad Muzaffarnagar has also transferred funds to the tune of Rs. 2,36,30,000/- (Two Crore Thirty-Six Lakhs and Thirty Thousand) towards construction of road, to the concerned department i.e Public Works Department on 29.8.2024. In this respect a letter dated 2.9.2024, is also issued by Executive Officer, Muzaffarnagar to Executive Engineer, PWD. The copy of challan dated 29.8.2024 alongwith letter dated 2.9.2024 is marked and annexed as **ANNEXURE A2**. Public Works Department had issued tender for construction of road via notification dated 10.9.2024. The copy of notification dated 10.9.2024 issued by PWD is marked and annexed as **ANNEXURE A3**.

- ii. That in total there are 4 compost pits are located at different locations which are a) Kamala Nehru Vatika, South Civil Lines, Muzaffarnagar b) Kambal Wala Bagh c) Prempuri each having capacity of 3 MT. It is added that there are two compost pits at Kamala Nehru Vatika. The photographs of all compost pits are marked and annexed as ANNEXURE A4. It is further added that 4 composters are also placed at 4 different banquet halls for processing bulk wet waste generated in these banquet halls and nearby areas. The capacity of each composter is 500 liters. The photographs of these composters are marked and annexed as ANNEXURE A5. The Detailed Project Report is prepared by Nagar Palika Parishad, Muzaffarnagar for construction of Compost Plant, for processing 5 tons of wet waste. The copy of Detailed Project Report is marked and annexed as **ANNEXURE A6**
- iii. That the said application was submitted by M/S Environmental Techno & M/S Daya Charan and Company (Joint Venture) for disposal of legacy waste. It is reiterated that the on 07.01.2022 Nagar Palika Parishad through Executive Officer entered into tri-partite agreement with C&D Services, Uttar Pradesh Jal Nigam and M/s 'Environmental Techno & M/s Daya Charan and Company' for disposal of legacy waste. The period of agreement was of eight months. As per the agreement the company shall process legacy waste at Prempuri near Machli Talab and Kidwai Nagar. The agreement was for disposal of 224655 MT Legacy Waste. The contract was completed by the Company.
- iv. That for disposal of residue M/S Environmental Techno entered into an agreement with Silvertan papers Limited on 20<sup>th</sup> April 2023.

Second Party i.e Silvertoan has mentioned that it has got all the requisite conditions for consuming RDF. This agreement was valid for 1 year. The Copy of the said agreement dated 20<sup>th</sup> April 2023 is marked and annexed as ANNEXURE A7.

- v. That regarding the sites mentioned in the order dated 23.9.2024, passed by this Hon'ble Tribunal are Prempuri, Navin Mandi, Latoor Singh Road, Thana Bhawan Road, Sambhalhera, Laddhawala, Share Rehman, it is submitted that they are being cleaned on daily basis. Mobile Compactor Machine is placed at Prempuri / Thana Bhawan Road Site, Photograph of the site with as well as without Mobile Compactor Machine is placed on record as ANNEXURE A8. At Latoor Singh / Nayi Mandi Gate No.3 another portable Compactor Machine is already sanctioned and is ready to be placed at this location. It will be placed in within next 15 days. Current photographs of this location i.e Latoor Singh / Nayi Mandi Gate No.3 is placed on record as ANNEXURE A9. It is submitted that at Ladhawala "DHALAO GHAR" has been completely shut down. Latest photograph of the site i.e Ladhawala is marked as ANNEXURE A10. Sambhalhera is outside the municipal limits of Nagar Palika Parishad, Muzaffar Nagar.
4. That it is submitted that in compliance of the order dated 3<sup>rd</sup> July 2024 passed by Hon'ble National Green Tribunal, the details of work in progress has been provided in the forgoing paragraphs. Nagar Palika Parishad Muzaffarnagar further submits that all the waste has been cleared from sensitive areas.

5. That it is not the case where no attempt was made by Nagar Palika Parishad Muzaffar Nagar for disposing of legacy waste. Nagar Palika Parishad issued a e-tender dated 5.10.2023 for disposing of 5 Lakh MT of legacy waste. The copy of e-tender is marked and annexed as ANNEXURE A11. It is submitted that no one participated in the said tender and therefore the said tender elapsed.
6. That now GC International has undertaken to process legacy waste free of cost, which is apparent from letter dated 9.6.2024. The copy of the letter dated 9.6.2024 is marked and annexed as ANNEXURE A12. It is submitted that the proposal in this regard had already been passed by the Municipal Board in their Board meeting dated 20.7.2024. The Copy of Board Resolution dated 20.7.2024 is also annexed as ANNEXURE A13.
7. That it is necessary to point out that State Government of Uttar Pradesh has directly entered into the contract with the said company namely GC International, for disposal of waste of three districts i.e Noida, Ghaziabad and Muzaffarnagar. The copy of agreement and other details have been placed on record by Nagar Palika Parishad, Muzaffarnagar in its previous report. As per the document provided by GC International as well as Government of UP it is Waste to Energy plant.
8. That Executive Officer, Nagar Palika Parishad, Muzaffarnagar had asked GC International the timeline for processing the legacy waste. In its detailed reply dated 13<sup>th</sup> June 2024, GC International had stated that their phase 1 is focussed on preparing the plot for the construction of the Waste to Energy plant which they will start by the end of August – beginning September 2024, subject to access road is accessible. In this regard it has been already stated above that PWD had notified e-tender and the duration of the work

mentioned in the said e-tender is of 6 months. At the end of phase 1 approximately 180,000 m<sup>3</sup> of waste will be cleared from the landfill within two years in compliance with all applicable the rules and guidelines to process waste in safe and environmentally sound manner. The further projected 400,000 m<sup>3</sup> of waste will be cleared when the waste to energy plant is in full operation at the end of phase 2. The current landfill/ Muzaffarnagar recycle facility will become a functioning recycle facility again due to clearance of the legacy waste. It is further mentioned in the letter dated 13<sup>th</sup> June 2024 will be clearing and processing of legacy waste into RDF in the first parts of the landfill as well as the adjacent plot. The copy of the letter dated 13<sup>th</sup> June 2024 is marked as **ANNEXURE A14**.

9. That in the last Report dated 26.6.2024 Nagar Palika Parishad had undertaken to initiate tendering process regarding fresh waste. Accordingly, and in compliance of the order dated 3<sup>rd</sup> July 2024 passed by National Green Tribunal in total 3 times e-tender were notified regarding disposal of 42120 MT Fresh Waste. The first e-tender was notified on 22.6.2024 and opened on 13.7.2024. Only one firm participated in the said e-tender and therefore it was not accepted. The copy of e-tender dated 22.6.2024 along with report is marked as **ANNEXURE A15**. Second Tender was notified on 30.07.2024. It was opened on 23.08.2024. Three firms participated in the said tender namely a) AAYUSHI HYGIENE and CARE, b) AAKANKSHA ENTERPRISES and c) GREENUS ENERGY and SOLUTIONS. But all the three firms failed to comply with the conditions of the tender and therefore it also elapsed. It is added that none of the three firms held minimum 1 year of experience regarding leachate treatment. The copy of e-tender dated 30.7.2024 is marked as **ANNEXURE A16**. Third time fresh tender is again notified on 10.9.2024 which will open on

318  
7

20.9.2024. The copy of new e-tender dated 10.9.2024 is marked and annexed as ANNEXURE A17.

10. That in the end it is necessary to mention that municipal bodies, even though being autonomous bodies cannot function without control of the State Government. Every decision regarding any policy taken by municipal body is continuously monitored by state government. This reality is not only a mere fact but rather it is enacted law. The State Government excises its control over local municipal bodies through section 2 of "The Uttar Pradesh State Control over Public corporation act of 1975".

11. It is humbly prayed that the present Reply along with documents be taken on Record.

Date : 19<sup>th</sup> September 2024.

  
अधिसासी अधिकारी  
नगर पालिका परिषद  
मुजफ्फरनगर

NAGAR PALIKA PARISHAD, MUZAFFARNAGAR  
THROUGH EXECUTIVE OFFICER

BEFORE THE NATIONAL GREEN TRIBUNAL, PRINCIPAL  
BENCH, NEW DELHI

ORIGINAL APPLICATION NO. 53 of 2024

IN THE MATTER OF

FARHA KHAN .....Applicant

VERSUS

STATE OF UTTAR PRADESH AND ORS. ....Respondents

AFFIDAVIT

I, Pragya Singh aged about 38 years W/O Pawan Kumar Singh working as Executive Officer of Nagar Palika Parishad, Muzaffarnagar, Uttar Pradesh, residing at Executive Officer Government Houses, South Civil Line, Muzaffarnagar present at New Delhi do hereby state on oath and declare as under :

1. That I am the Executive Officer of Nagar Palika Parishad, Muzaffarnagar, Uttar Pradesh in the above-mentioned matter and as my official capacity. I am well conversant with the facts of the case hence competent to swear this affidavit.
2. That I was transferred to Muzaffarnagar and I took charge as Executive Officer, Nagar Palika Parishad, Muzaffarnagar on 16.02.2024. I also state that all the necessary documents attached in the reports / reply are in custody of Nagar Swasthya Adhikari, Nagar Palika Parishad, Muzaffarnagar and he is head of the department i.e Health and Sanitation. All supervisors as well as Safai Karmchari

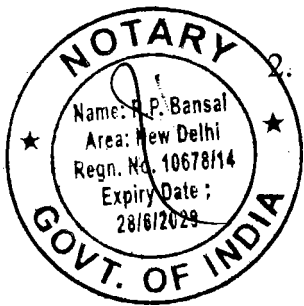

comes under Nagar Swasthya Adhikari and his role is to monitor and implementation of daily waste management, door to door collection, daily cleaning.

3. That before my transfer to Nagar Palika Parishad, Muzaffarnagar, Dr. Atul Nagar Swasthya Adhikari was responsible for scientific disposal of waste as well as all MSW waste management. He is responsible for implementation of MSWMR 2016. It has been instructed by me to Nagar Swasthya Adhikari to follow all the waste related guidelines.
4. That I have read and understood the accompanying reply paragraph \ to \ , along with Annexures, which has been prepared by the lawyer upon my instructions. I say that whatever is stated therein are true and correct on the basis of documents made available to me by Nagar Swasthya Adhikari, which are also available on record and to the best of my knowledge and belief.
5. That the Annexures are True Copies of their original.

  
 अधिकाारी अधिकाारी  
 DEPONENT  
 नगर पालिका परिषद  
 मुजफ्फरनगर

Verification:

  
 IDENTIFIED BY

I, above named deponent do hereby verify that the contents of the above affidavit are true and correct to my knowledge and belief.

Nothing material has been concealed therefrom.

Verified at New Delhi on 19 SEP 2024 day of September, 2024.



ATTESTED  
  
 Notary Public, Delhi  
 (As Presented)  
 19 SEP 2024

  
 अधिकाारी अधिकाारी  
 DEPONENT  
 नगर पालिका परिषद  
 मुजफ्फरनगर

321

10

ANNEXURE - A1

Department of Urban Development  
Government of Uttar Pradesh

Date: 5<sup>th</sup>. November, 2018

To,

**M/s GC International**  
H.N. 320, Sector 21B,  
Faridabad, Haryana – 121003  
e. mail: ata@gc-bv.com

AND

**Honorary Consul of the Kingdom of the Netherlands**  
620, Cyber Heights, Vibhuti Khand, Gomti Nagar,  
Lucknow-226010  
e. mail: nlconsulate.lucknow@gmail.com

**Subject:** Letter of Acceptance to Set up Waste to Energy Plant at Gaziabad- NOIDA and Muzzaffarnagar, Uttar Pradesh.

The State Government organised Investors Summit at Lucknow on 21-22 February, 2018. In above summit, representatives of various industries expressed their interest in making investment for the purpose of setting up of waste to energy plant for processing of municipal solid waste in the State, provided land is made available to them on long term lease and there is assured supply of municipal solid waste. The Government considered the above proposals and notified the "Uttar Pradesh Solid Waste Management Policy" vide G.O. No. 2221/Nine-5-18-352Sa/2016, dated 29-06-2018.

2. The Policy provides for private participation and investment in solid waste management (collection, segregation, transportation, processing and disposal). The Policy has a provision that "in cases where any proposal from private Entity / Investor / NGO / Organization is received in the Government / Directorate or Urban Local Body for solid waste management activities in any Urban Local Body (ULB) or group of ULBs in the State, without asking for any financial assistance, whether one time or recurring and the private investor or above mentioned categories of entities' requirement is only the land on long term lease (25-30 years) and the solid waste from the Urban Local Body, then in such cases, the proposal will be scrutinized by the State

Level Committee constituted for the purpose of appraising the Public Private Partnership projects and permissions for implementation of the project will be granted based on the recommendations of the Committee by the authority competent to approve the grant of long term lease of the ULB land at the rate of one rupee per square meter annually. The approval for the lease of the land will be with the following mandatory conditions: (i) The land required for the implementation of the project available with the ULB will be given on lease with the lease rent @ Rs.1 per sq.mt. per year; (ii) the land assigned to the developer would not be used for any other activity except for approved project activities; (iii) the project proponent is not allowed to mortgage the land; (iv) access road / electricity / water / streetlight / drainage / sewer will be provided by the ULB up to the Plot. The developer will be entitled to sale or charge for the products and by- products produced in the process of solid waste management."

3. In pursuance of the above policy objectives. Construction & Design Services, Uttar Pradesh Jal Nigam, Lucknow invited proposals from the willing parties through an open tender notice published through its Letter No. 383/GM\_N-8/IKarya-10/87 Dated 05/07/2018.

4. M/s GC International, Consulate – Kingdom of the Netherlands has participated and submitted their proposal for establishing waste to energy plant at Ghaziabad-NOIDA and Muzaffarnagar. The Public-Private-Partnership projects Bid Evaluation Committee (PPPBE) has gone through the presentation made by your company on 14.09.2018 and after due considerations has recommended the project for implementation. The Competent Authority has approved the proposal.

5. Terms and Condition for Implementation of the Project:

- a. Your company has been assigned to set up the plants in Ghaziabad and Muzaffarnagar city.
- b. The Company need to co-ordinate with the respective Local Authority (Urban Local Body) for identification and finalization of the site / land for the setting up and operation of the plant.
- c. Once the Land is identified, the proposal for lease deed of the Land will be prepared by respective Urban Local Body in conformity to the State Solid Waste Management Policy which provides following conditions for the lease deed:

- (i) The land required for the implementation of the project available with the ULB will be given on lease of 25-30 years on the lease rent @ Rs.1 per square meter annually.
- (ii) The land assigned to the developer would not be used for any other activity except for approved project activities.
- (iii) The project proponent is not allowed to mortgage the land or create any kind of encumbrance on the land.

6. The Company need to prepare and present their Detailed Project Report (DPR) for the project to the Local Authority (Urban local Body) as early as possible and it is required that all project related planning, designing, construction and other activities for the operation of the Waste to Energy Plant shall be completed as early as possible and in no circumstances it shall exceed more than Thirty Six (36) months from the date of issuance of this Letter of Acceptance.

*Manoj*  
5.11.2018  
(Manoj Kumar Singh)  
Principal Secretary  
Department of Urban Development  
Government of Uttar Pradesh.

**Copy to:**

1. Divisional Commissioner, Meerut with a request to provide the necessary guidance and support to the Project Proponent for execution of the project.
2. District Magistrate, Gaziabad and Muzzaffarnagar for facilitating the implementation of the project.
3. Municipal Commissioner, Gaziabad for taking all the necessary steps for implementation of the project.
4. Executive Officer, Mjuzaffarnagar Municipal Council for taking all the necessary steps for implementation of the project.

**धनराशि जमा करने का चालान फार्म (Revised)**

उपकोषागार/बैंक का नाम व शाखा

भारतीय स्टेट बैंक रेलवे रोड़ मुजफ्फरनगर

- 1- जिस व्यक्ति (पदनाम यदि आवश्यक हो) या संस्था का नाम जिससे धनराशि जमा की जा रही है उसका नाम
- 2- पता

अधिशासी अभियन्ता  
निर्माण खण्ड-1 लो0नि0वि0  
मुजफ्फरनगर।

- 3- पंजीकरण संख्या/पक्ष का नाम व वाद संख्या (यदि आवश्यक हो)

- 4- जमा की जा रही धनराशि का पूर्ण विवरण (धनराशि किस हेतु जमा की जा रही है तथा किस विभाग के पक्ष में जमा की जा रही है)

वित्तीय वर्ष 2024-25 में वेस्ट टू एनेजी प्लान्ट के पहुंच मार्ग हेतु किदवईनगर स्थित कूड़ा प्लान्ट को जाने वाले रास्ते पर सी0सी0 एवं नाली निर्माण का कार्य।

जमा राशि - 0300  
1501.21 अ.प. - 1986

- 5- चालान की सकल राशि

23630000.00

- 6- चालान की निवल राशि

23630000.00

- 7- लेखाशीर्षक का पूर्ण विवरण/लेखा शीर्षक की मुहर

8782 Remittance

- 8- लेखा-शीर्षक का 13 डिजिट कोड

मुख्य लेखा शीर्षक	उपमुख्यशीर्षक	लघु-शीर्षक	उप-शीर्षक	व्यौरेवार-शीर्षक	धनराशि अंकों में
8 7 8 2	0 0	1 0 2	0 1	0 1	23630000.00
					23630000.00

धनराशि शब्दों में

Rupees Two Crore ThirtySix Lakh Thirty Thousand Only

चालान में अधिशासी अभियन्ता निर्माण खण्ड-1 लो0नि0वि0 विभागीय अधिकारी के हस्ताक्षर मुहर सहित मुजफ्फरनगर

अधिशासी अधिकारी अध्यक्ष नगर पालिका परिषद, मुजफ्फरनगर जमा कर्ता का नाम व हस्ताक्षर

*Meenakshi Swami*

केवल उपकोषागार/बैंक के प्रयोगार्थ

चालान संख्या HT 75145  
दिनांक

अंकों में रू0  
शब्दों में रू0

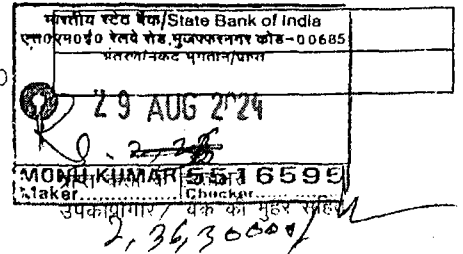
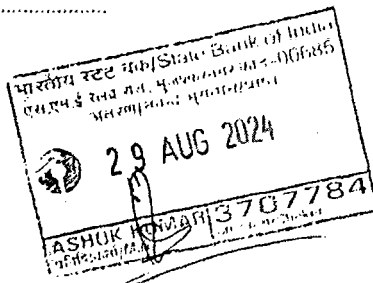

325

कार्यालय नगर पालिका परिषद, मुजफ्फरनगर।

प्रेषक,

अधिकाारी अधिकाारी,  
नगरपालिका परिषद,  
मुजफ्फरनगर।



सेवा में,

अधिकाारी अभियन्ता,  
निर्माण खण्ड-1 लोक निर्माण विभाग,  
मुजफ्फरनगर।

पत्रांक: 1023/सा0प्र0/2024-25

दिनांक: 02/09/2024

विषय:- वित्तीय वर्ष 2024-25 में वेस्ट टू एनेर्जी प्लान्ट के पहुँच मार्ग हेतु किदवईनगर स्थित कूड़ा प्लान्ट को जाने वाले रास्ते पर सी0सी0 एंव नाली निर्माण के कार्य के सम्बन्ध में।

महोदय,

कृपया उपर्युक्त विषयक आपके कार्यालय पत्रांक संख्या-1353/2सी, व 1354/2सी दिनांक:18.05.2024 का सन्दर्भ ग्रहण करने का कष्ट करें, जिसके द्वारा इस कार्यालय के पत्रांक संख्या-2626/सा0प्र0/2023-24 दिनांक 30.03.2024 के क्रम में वित्तीय वर्ष 2024-25 में वेस्ट टू एनेर्जी प्लान्ट के पहुँच मार्ग हेतु किदवईनगर स्थित कूड़ा प्लान्ट को जाने वाले रास्ते पर सी0सी0 एंव नाली निर्माण के कार्य हेतु रू0 अंकन 236.30 लाख का विस्तृत प्रांकलन तैयार करते हुए प्रांकलन की धनराशि अंकन 236.30 लाख डिमान्ड ड्राफ्ट कार्यालय अधिकाारी अभियन्ता, निर्माण खण्ड-1, लो0नि0वि0, मुजफ्फरनगर के पक्ष में जारी करने हेतु अनुरोध किया गया है, जिसके अनुपालन में अधोहस्ताक्षरी के कार्यालय द्वारा अंकन-236.30 लाख रुपये की धनराशि को निर्धारित चालान के माध्यम से दिनांक 29 अगस्त 2024 को निर्धारित ट्रेजरी कोड 0300 डिवीजन कोड 1986 लेखा शीर्षक 8782 Remittance में धनराशि हस्तान्तरित की जा चुकी है।

अतः आपसे अनुरोध है कि उक्त कार्य को शीघ्र अति-शीघ्र प्रारम्भ कराये जाने का कष्ट करें।

भवदीय

अधिकाारी अधिकाारी,  
नगरपालिका परिषद,  
मुजफ्फरनगर।

प्रतिलिपि:- अपर जिलाधिकारी (प्रशासन)/प्रभारी अधिकाारी स्थानीय निकाय, मुजफ्फरनगर की सेवा में सूचनार्थ प्रेषित।

अधिकाारी अधिकाारी,  
नगरपालिका परिषद,  
मुजफ्फरनगर।

**कार्यालय अधीक्षण अभियन्ता सहारनपुर वृत्त, लो०नि०वि०, सहारनपुर**  
**ई-प्रोक्वोरमेंट अति अल्पकालीन निविदा सूचना**

क्र. 6908/28एम०एस०-एस०वृत्त/24

दिनांक: 10/9/24

महामोहम राजमणल उ०प्र० की ओर से निम्न कार्य हेतु ऑन लाईन निविदाये <http://etender.up.nic.in> के माध्यम से ऑनलाइन में आर्बसाइड रजिस्टर्ड फर्म से दिनांक 18.08.2024 की प्रातः 11.00 बजे से दिनांक 24.08.2024 को अपराह्न 12.00 बजे तक आमन्त्रित की जाती है। निविदा की प्री-क्वालिफिकेशन/टेक्निकल बिड दिनांक 24.08.2024 को अपराह्न 12/30 बजे अशोहसहायरी के कार्यालय कक्ष में उपस्थित रजिस्टर्ड फर्म के अधिकृत प्रतिनिधि को समक्ष गठित समिति के सदस्यों द्वारा ऑन लाईन खोली जायेगी। टेक्निकल बिड में क्वालीफाईड पाये गये ठेकेदारों की फाईनेन्शियल बिड खोलने की तिथि एवं समय <http://etender.up.nic.in> पर अपलोड कर दी जायेगी। शासनादेश सं० 317/देईस-1-2018-178 सा०/2006टी०सी०-1 दिनांक 10.04.2019 के अन्तर्गत निविदा सूचना में अंकित शालिका के कॉलम 5 में अंकित बरोहर धनराशि एवं कॉलम 7 में प्रदर्शित निविदा प्रपत्र का मूल्य जी०एस०टी० सहित ऑनलाइन (E-Banking द्वारा) जमा कराना अनिवार्य होगा। कार्यालय बन्द होने अथवा छुट्टी होने की दशा में प्री-क्वालिफिकेशन/टेक्निकल बिड एवं फाईनेन्शियल बिड उसी क्रम एवं समयानुसार अगले कार्य दिवस में खोली जायेगी। कार्य का विवरण निम्नवत है:-

क्र. सं.	जनपद	कार्य का नाम	कार्य की अनुमानित लागत (लाख ₹० में)	बरोहर धनराशि (लाख ₹० में)	कार्य पूर्ण करने की अवधि	निविदा प्रपत्र का मूल्य जी०एस०टी० सहित	ठेकेदार के पंजीयन की श्रेणी
1	2	3	4	5	6	7	8
1	मुजफ्फरनगर	वित्तीय वर्ष 2024-25 में बस्ट टू एनर्जी प्लान्ट के पहुच मार्ग हेतु कियदवई नगर स्थित कूड़ा प्लान्ट को जाने वाले रास्ते पर सीसी एवं नाली निर्माण का कार्य।	185.00	11.25	06 माह	2000+300+ 414 = 2714.00	मार्ग श्रेणी ए, सी

निविदा से सम्बन्धित नियम/शर्त तथा विवरण <http://etender.up.nic.in> पर उपलब्ध है। फर्म/ठेकेदारों को शासनादेश सं० 879(1)/23-7-2020 दिनांक 25.08.2020 में लिहित प्राविधानुसार प्रहरी एप्लीकेशन पर वांछित प्रपत्र अपलोड करना अनिवार्य होगा।

अधिशारी अभियन्ता  
 निर्माण खण्ड-1, लो०नि०वि०  
 मुजफ्फरनगर

अधीक्षक अभियन्ता  
 सहारनपुर वृत्त, लो०नि०वि०  
 सहारनपुर

कार्यालय अधीक्षण अभियन्ता 327 सहरनपुर वृत्त, लो0नि0वि0, सहरनपुर  
ई-प्रोक्चोरमेन्ट अति अल्पकालीन निविदा सूचना

पत्रांक : 6908 / 28एम0एस0-एस0वृत्त / 24

दिनांक : 10.09.2024

महामहिम राज्यपाल उ0प्र0 की ओर से निम्न कार्य हेतु ऑन लाईन निविदायें <http://etender.up.nic.in> के माध्यम से लोनिवि में आर्थराइज्ड रजिस्टर्ड फर्म से दिनांक 18.09.2024 की प्रातः 11.00 बजे से दिनांक 24.09.2024 को अपराह्न 12.00 बजे तक आमन्त्रित की जाती है। निविदा की प्री-क्वालिफिकेशन/टेक्निकल विड दिनांक 24.09.2024 को अपराह्न 12:30 बजे अरोहस्ताक्षरी के कार्यालय कक्ष में उपस्थित रजिस्टर्ड फर्म के अधिकृत प्रतिनिधि के समक्ष गठित समिति के सदस्यों द्वारा ऑन लाईन खोली जायेगी। टेक्निकल विड में क्वालीफाईड पाये गये ठेकेदारों की फाईनेन्शियल विड खोलने की तिथि एवं समय <http://etender.up.nic.in> पर अपलोड कर दी जायेगी। शासनादेश सं0 317/तेईस-7-2018-176 सा0/2006टी0सी0-1 दिनांक 10.04.2019 के अन्तर्गत निविदा सूचना में अंकित तालिका के कॉलम 5 में अंकित धरोहर धनराशि एवं कॉलम 7 में प्रदर्शित निविदा प्रपत्र का मूल्य जी0एस0टी0 सहित ऑनलाईन (E- Banking द्वारा) जमा कराना अनिवार्य होगा। कार्यालय बन्द होने अथवा छुट्टी होने की दशा में प्री-क्वालिफिकेशन/टेक्नीकल विड एवं फाईनेन्शियल विड उसी क्रम एवं समयानुसार अगले कार्य दिवस में खोली जायेगी। कार्य का विवरण निम्नवत् है:-

क्र. सं.	जनपद	कार्य का नाम	कार्य की अनुमानित लागत (लाख रू0 में)	धरोहर धनराशि (लाख रू0 में)	कार्य पूर्ण करने की अवधि	निविदा प्रपत्र का मूल्य जी0एस0टी0 सहित	ठेकेदार के पंजीयन की श्रेणी
1	2	3	4	5	6	7	8
1	मुजफ्फरनगर	वित्तीय वर्ष 2024-25 में वेस्ट टू एनर्जी प्लान्ट के पहुच मार्ग हेतु किदवई नगर स्थित कूड़ा प्लान्ट को जाने वाले रास्ते पर सीसी एवं नाली निर्माण का कार्य।	185.00	11.25	06 माह	2000+300+414 = 2714.00	मार्ग श्रेणी ए, वी

निविदा से सम्बन्धित नियम/शर्तें तथा विवरण <http://etender.up.nic.in> पर उपलब्ध है। फर्म/ठेकेदारों को शासनादेश सं0 879(1)/23-7-2020 दिनांक 25.08.2020 में निहित प्राविधानुसार प्रहरी एप्लीकेशन पर वांछित प्रपत्र अपलोड करना अनिवार्य होगा।

अधिशाली अभियन्ता  
निर्माण खण्ड-1, लो0नि0वि0  
मुजफ्फरनगर

अधीक्षण अभियन्ता  
सहरनपुर वृत्त, लो0नि0वि0  
सहरनपुर



329  
18

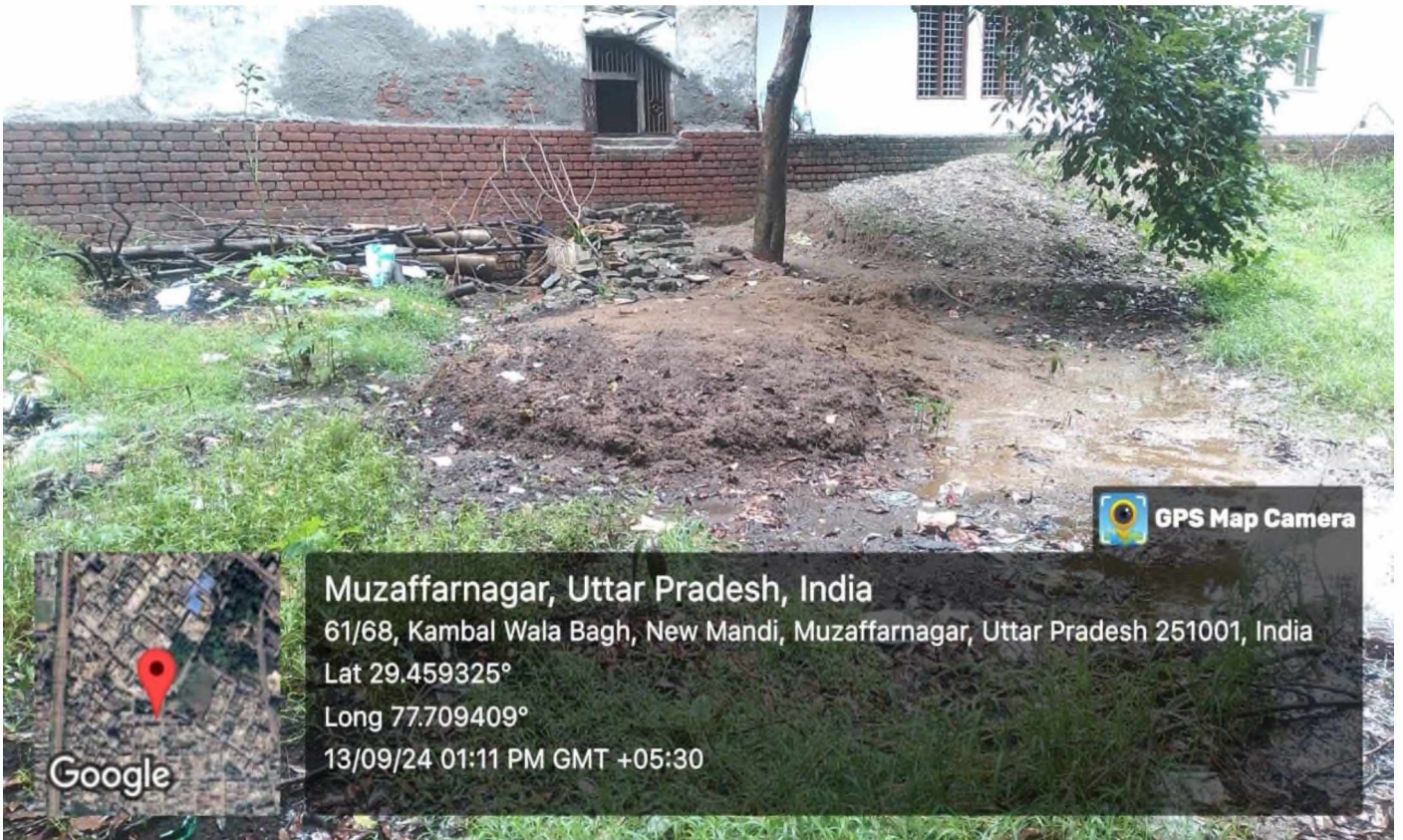

 GPS Map Camera

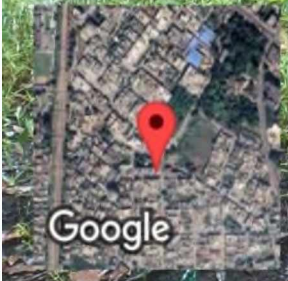

Muzaffarnagar, Uttar Pradesh, India  
61/68, Kambal Wala Bagh, New Mandi, Muzaffarnagar, Uttar Pradesh 251001, India  
Lat 29.459325°  
Long 77.709409°  
13/09/24 01:11 PM GMT +05:30

19<sup>330</sup>



 GPS Map Camera

Muzaffarnagar, Uttar Pradesh, India  
FM5X+W8G, Civil Lines South, Muzaffarnagar, Uttar Pradesh 251001, India  
Lat 29.459599°  
Long 77.697893°  
13/09/24 01:14 PM GMT +05:30

Google

331

20



 **GPS Map Camera**

Muzaffarnagar, Uttar Pradesh, India  
FM9J+383, Prempuri, Muzaffarnagar, Uttar Pradesh 251002, India  
Lat 29.467652°  
Long 77.680568°  
13/09/24 04:29 PM GMT +05:30

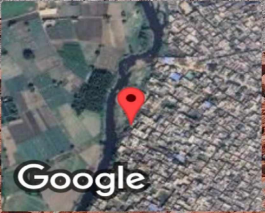

Google







335

24



336  
25



337  
25

ANNEXURE -A6

**NAGAR PALIKA PARISHAD, MUZAFFARNAGAR**

**SWACHH BHARAT MISSION-NAGARIYA**



**D.P.R**

**DETAILED ESTIMATE OF WET WASTE PROCESSING**

**UNIT FOR 5 TONS AT NAGAR PALIKA PARISHAD,**

**MUZAFFARNAGAR**

**ESTIMATED COST- 39.90 LAKHS**

**YEAR - 2024-**

  
**Executive Officer,  
Nagar Palika Parishad,  
Muzaffarnagar**

338

OFFICE NAGAR PALIKA PARISHAD MUZAFFAR NAGAR  
Wet Waste Processing Unit for 5 Tons

<b>ABSTRACT OF ESTIMATE (FORM "J")</b>			
	Cost of Structure	Rs.	3376594.44
	Add 18% GST	Rs.	607787.00
	Total	Rs.	3984381.44
	Add Sign Board	Rs.	5000.00
	<b>Grand Total:-</b>	Rs.	<b>3989381.44</b>
	<b>Say in Lakhs</b>	Rs.	<b>39.90</b>

  
अवर अभियन्ता (निर्माण)  
नगर पालिका परिषद  
मुजफ्फरनगर

  
सहायक अभियन्ता (निर्माण)  
नगर पालिका परिषद  
मुजफ्फरनगर

(28)  
Bill of Quantity

Wet Waste Processing Unit for 5 Tons

S.N.	Item Of Work	Unit	Quantity	Rate	Amount	Remark
1	2	3	4	5	6	7
1	Surface Dressing of ground including removing vegetation and in-situ fill not exceeding 15 cm deep and disposal of rubbish, load up to 50 m and lift up to 1.5 m. All kinds of soil.	Sqm	700.07	12	8400.84	
2	Earth work in surface excavation not exceeding 30 cm in depth but exceeding 1.5m in width as well as 10 sqm on plan including getting out and disposal of excavated earth upto 50 m and lift upto 1.5 m, as directed by Engineer-in-Charge 2.1.1. All kinds of soil.	Cum	201.74	110.00	22191.40	
3	Excavating, supplying and filling of local earth (including royalty) by mechanical transport upto a load of 5Kmt also including ramming and watering of the earth in layers not exceeding 20cm in trenches, plinth, sides of foundation etc. complete	cum.	66.50	144.40	9602.60	
4	Providing & Laying of C.C. in 1:6:12 with c/s and 40 mm G.S.B. in foundation of Floor i/c all labour, materials and T&P etc. As Per PWD S.I.No-273.	Cum.	147.28	3150.00	463932.00	
5	R.C.C. work in column 1:2:4 with cement, coarse sand, 20 mm gauge stone grit i/c all complete As Per PWD S.I.No-283	Cum.	50.27	8100.00	407163.55	
6	M150 Brick Work in 1:6 c/s mortar in sub-structure i/c all labour & T&P etc. As Per PWD S.I.No-282	Cum.	104.18	3800.00	395884.00	
7	12 mm thk Internal Plaster in 1:3 with c/s mortar in wall i/c all materials, labour & T&P etc. S.I-586	Sqm.	1250.49	185.00	231340.65	
8	M.S.Iron work in plain work such as R.C.C. Work i/c all complete					
9	Providing & laying steelbars including cutting binding, placing and complete in all respect	Qtl	47.10	6500	306150.00	
10	Mild steel or iron work in heavy size such as trusses, build up gates, record racks, roof work, gates etc wrought to required from including drilling holes riveting or welding where necessary and their fixing required for proper completion of the work. As Per PWD S.I.No-503	Qtl	55.00	6300.000	346500.00	
11	Mild steel or iron work of small size and sections such as holding down bolts, hold fast, tie rods, grating etc. (when not included in an overall rates) wrought to required shape as necessary for bending etc including supply of steel and its wastage including cost of bolts, nuts if required, welding, grinding and making holes as required for completion of work As Per PWD S.I.No-504	Qtl	12.00	5400.000	64800.00	
12	Providing and fixing pre-coated galvanised iron sheets (size, shape and pitch of corrugation as approved by Engineer-in-charge) 0.50 mm (+0.05%) total coated thickness with zinc coating 120 grams per sqm as per IS:277, in 240 mpa steel grade, 6-7 microns epoxy primer on both side of the sheet and polyester top coat 15-18 microns. Sheet should have protective guard film of 25 microns minimum to avoid scratches during transportation and should be supplied in single length upto 12 metre or as desired by Engineer-in-charge. The sheet shall be fixed using self-drilling nails or	Sqm	770.00	547.000	393840.00	

अथर अभियन्ता (निर्माण)  
नगर पालिका परिषद  
मुजफ्फरनगर

सहायक अभियन्ता (निर्माण)  
नगर पालिका परिषद  
मुजफ्फरनगर

13	Providing and laying rectified Glazed Ceramic floor tiles of size 300 x 300 mm or more (thickness to be specified by the manufacturer), of 1st quality conforming to IS: 15622, of approved make, in colours white, Ivory, Grey, Fume Red Brown, laid on 20 mm thick cement mortar 1:4 (1 Cement: 4 Coarse Sand), jointing with slurry white cement and matching pigments etc, complete	Sqm	24.12	997.000	24048.99
14	Providing and laying rectified Glazed Ceramic floor tiles of size 300 x 300 mm or more (thickness to be specified by the manufacturer), of 1st quality conforming to IS: 15622, of approved make, in all colours, shades, except white, Ivory, Grey, Fume Red Brown, laid on 20 mm thick cement mortar 1:4 (1 Cement: 4 Coarse Sand), jointing with slurry white cement and matching pigments etc, complete	Sqm	9.72	1053.000	10235.16
15	Distempering(First coat) with oil bound distemper of approved brand and manufacture and of required shade on undecorated wall surface to give an even shade over and including a priming coat with cement primer of approved brand and manufacture such as Berger, J & N Shallmar, Aslan Paints after thoroughly brushing the surface free from mortar dropping and other foreign matter and also including preparing the surface even with Plaster Plaster of Paris or approved approved synthetic synthetic material and sand papored smooth including cost of all materials.	Sqm	1250.49	79.000	98788.71
16	Painting of wood or iron work including sand preparing rubbing and cleaning as required for proper completion of work (two coats)As Per PWD S.I.No-644	Sqm	711.41	49.000	34859.09
17	Painting or Varnishing on Iron works in small areas or new wood work with one coat of ready mixed priming paint & one coat of approved superior quality ready mixed paint of clear synthetic varnish including supply of all materials, labour and t&P etc. required for proper completion of the work paint to be used should confirm to theAs Per PWD S.I.No-644	Cum	6.30	66.00	415.80
18	Providing and applying putty of 2mm thickness over plastered surface to prepare the surface even and smooth complete	Each	1.00	104.000	104.00
19	Supply and fixing 32mm thick flush door all complete fitting	Sqm	3.24	1405.00	4552.20
20	Supply and fixing aluminium flush door all complete fitting bathroom and Latrin 32mm thick flush door all complete fitting	Each	2.00	3300.00	6600.00
21	Supply and fixing 32 mm thick flush door ply wood with handle fitting all complete	Sqm	32.00	1405.00	44960.00
22	Wiring point for light with 1.5 sq. mm. PVC Insulated single core aluminium conductor cable in heavy guage rigidsteel conduit pipe on surface, complete with 8 SWG GI earth continully wire, plano type switch and ceilingrose/angle/ batton holder on 3 mm. thick phenolic laminated backelito-sheet etc. complete in all respect, as	Each	22.00	475.000	10450.00

  
 अवर अभियन्ता (निर्माण)  
 नगर पालिका परिषद  
 मुजफ्फरनगर

  
 सहायक अभियन्ता (निर्माण)  
 नगर पालिका परिषद  
 मुजफ्फरनगर

30  
341

23	Wiringpoint for fan /fresh air fan (lightduty exhaustfan) with 1.5 sq.mm PVC Insulated single core aluminium conductor cable in heavy guage rigidsteel conduit . pipe on surface, complete with 8 SWG GI earth continuity wire, plano type switch & collingrose on 3 mm. thick phenolic laminated backelito sheet etc, complete in all, as directed	Each	22.00	623.000	13706.00
24	Wiring Point for plug with 1.5 sq. mm. PVC Insulated single core aluminiumconductor cable in heavy guage rigidsteel conduit pipe on surface, complete with 8 SWG GI earth continuity wire and plano type switch and socket etc. complete in all respect.	Each	22.00	268.000	5896.00
25	S/F of 18w howells make all fitting complete MR	Each	10.00	300.000	3000.00
26	S/F of LED 12w howells make all fitting complete MR	Each	35.00	170.000	5960.00
27	Septic tank of appropriate capacity for 2 years cleaning interval for 50 users	Nos	1.00	160000.000	160000.00
28	S/F of low density polythene seamless one piece moulded tank and placing the same in proper position including all	Ltr	2000.00	11.000	22000.00
29	Providing and fixing GI/PVC pipe all fitting	Each	1.00	15000.000	15000.00
30	Providing and fixing sanitary pipe all fitting	Each	1.00	10000.000	10000.00
31	Providing and fixing WC pan median type with cast iron P and S trap all complete with automatic flushing	Each	1.00	3175.000	3175.00
32	Supply and fixing 25mm PVC pipe in position all complete	Each	394.60	235.000	92731.00
33	Supply and fixing 25mm PVC pipe in position all complete	Each	394.60	40.000	15784.00
34	Supply and fixing 30 mm dia socket	Each	900.00	20.00	18000.00
35	200 mm dia drilling and 350 mm dia running from ground level to 50 m below ground level in alluvial soil up to sand strata	RM	51.00	45.00	2295.00
36	Supply and lowering of 150 mm dia PVC plain casing pipe	RM	51.00	392.00	19992.00
37	Supply and fixing of 150 mm dia End Cap	Each	1.00	355.00	355.00
38	Supply and fixing of 150 mm dia Top Cap	Each	1.00	200.00	200.00
39	Supply and fixing of 150 mm dia Centerlizer	Each	1.00	200.00	200.00
40	P/F 650X400mm hand wash basin of white glazed earthen ware ISI marked (Hindustan neyer cera make ) i/c supply of all materials labour and t&p comp.	Nos	1.00	2300.00	2300.00
41	P/F flat back 465 mm x 355 mm x 265 mm size lipped from uninal basin of white glazed earther were first quality (Hindustan Nycer Make) S.I. mark S I No 304	Nos	1.00	900.00	900.00
42	P/F polyvinyl chloride (CPVC) pipe 20mm dia	Rm	10.00	240.00	2400.00
43	P/F polyvinyl chloride (CPVC) pipe 15mm dia	rm	25.00	160.00	4000.00
44	P/F bib brass bib cock 400 gms i/c all	Nos	8	720.00	5760.00
45	Making water connection of GI pipe line with GI main as in SI 210	Nos	1.00	500.00	500.00
46	PVC low level cisterns 10 ltr capacity with all internal fittine of PVC etc.	Nos	1.00	1200.00	1200.00
47	Handpump with submerciable	Nos	1.00	86431.46	86431.46
TOTAL					3376594.44
Say					3376594.44

  
 अवर अभियन्ता (निर्माण)  
 नगर पालिका परिषद  
 मुजफ्फरनगर

  
 सहायक अभियन्ता (निर्माण)  
 नगर पालिका परिषद  
 मुजफ्फरनगर

## Details of Measurements

### Wet Waste Processing Unit for 5 Tons

31

S.N.	Item Of Work	No.			L.	B.	H/D	Qty.	Unit
			3						
1	Surface Dressing of ground including removing vegetation and in-equalities not exceeding 15 cm deep and disposal of rubbish, lead up to 50 m and lift up to 1.5 m. All kinds of soil.	1	x	1	14.60	47.95		700.07	Sqm
2	Earth work in surface excavation not exceeding 30 cm in depth but exceeding 1.5m in width as well as 10 sqm on plan including getting out and disposal of excavated earth upto 50 m and lift upto 1.5 m, as directed by Engineer-in-Charge 2.1.1. All kinds of soil.								
	Short Wall	1	X	2	14.60	0.35	0.20	2.04	
	Long Wall	1	X	2	50.00	0.35	0.20	7.00	
	Pit Composting	1	x	36	5.80	2.00	0.20	83.52	
	Footing	1	x	35	1.50	1.50	1.00	78.75	
	Drain	1	x	10	14.60	0.25	0.25	9.13	
	Rainwater Harvesting Pit	1	x	2	28.00	0.25	0.25	3.50	
	Rainwater Harvesting Tank	1	x	5	0.45	0.45	0.60	0.61	
	Leachote Tank	1	x	1	3.00	3.00	1.80	16.20	
		1	x	1	7.00	0.60	0.30	0.99	
							Total	201.74	Cum
3	Excavating, supplying and filling of local earth (including royalty) by mechanical transport upto a lead of 5KM also including ramming and watering of the earth in layers not exceeding 20cm in trenches, plinth, sides of foundation etc. complete								
	Segregation Area	1	x	1	8.00	6.00	0.20	9.60	
	Storage Area	1	x	1	6.00	5.60	0.20	6.72	
	Office	1	x	1	4.43	5.45	0.20	4.82	
	Cleaning & Washing Area	1	x	1	3.00	5.45	0.20	3.27	
	Compost Machine Area	1	x	1	3.60	5.45	0.20	3.92	
	Shredder with Hopper	1	x	1	3.78	5.45	0.20	4.12	
	Toilet	1	x	1	1.80	2.70	0.20	0.97	
	Toilet	1	x	1	1.80	2.62	0.20	0.94	
	Adjacent to Toilet	1	x	1	3.10	5.45	0.20	3.38	
	Passage Area	1	x	1	3.00	47.94	0.20	28.76	
							Total	66.50	cum.
4	Providing & Laying of C.C. in 1:6:12 with c/s and 40 mm G.S.B. in foundation of Floor i/c all labour, materials and T&P etc.								
	Short Wall	1	X	2	20.00	0.35	0.15	2.10	
	Long Wall	1	X	2	47.95	0.35	0.15	5.03	
	Pit Composting	1	x	36	5.80	2.00	0.15	62.64	
	Segregation Area	1	x	1	6.79	5.57	0.15	5.67	
	Storage Area	1	x	1	5.30	5.34	0.15	4.25	
	Office	1	x	1	4.30	5.34	0.15	3.44	
	Cleaning & Washing Area	1	x	1	3.00	5.57	0.15	2.51	
	Compost Machine Area	1	x	1	3.60	5.57	0.15	3.01	
	Shredder with Hopper	1	x	1	4.30	5.57	0.15	3.59	
	Toilet	1	x	1	5.30	2.03	0.15	1.61	
	Open Area	1	x	1	3.10	5.55	0.15	2.58	

अवर अभियन्ता (निर्माण)  
नगर पालिका परिषद  
मुजफ्फरनगर

सहायक अभियन्ता (निर्माण)  
नगर पालिका परिषद  
मुजफ्फरनगर

	Passage Area	1	x	1	3.00	47.95	0.15	21.58	
	Footing	34	x	34	1.00	1.00	0.80	27.20	
	Rainwater Harvesting Pit	1	x	3	0.45	0.45	0.15	0.09	
	Rainwater Harvesting Tank	1	x	1	3.00	3.00	0.15	1.35	
	Leachate Tank	1	x	1	7.00	0.60	0.15	0.63	
							Total	147.28	cum
5	R.C.C. work in column/slab/wall 1:2:4 with cement, coarse sand, 20 mm gauge stone grit l/c all complete								
	Footing	1	x	40	1	1	0.3	12	
		1	x	40		0.13		5.34	
		1	x	40	0.10	0.10	0.10	0.04	
	Columns	1	x	40	0.45	0.45	2.20	17.82	
	Rainwater Harvesting Tank	1	x	1	3.00	0.23	1.80	1.24	
	Rainwater Harvesting cover	1	x	1	3.00	3.00	0.10	0.90	
	Toilet	1	x	1	5.45	1.80	0.45	4.41	
	Office	1	x	1	4.43	5.45	0.45	8.52	
							Total	50.27	Cum
6	M150 Brick Work in 1:6 c/s mortar in sub-structure l/c all labour & T&P etc.								
	Short Wall	1	X	1	14.60	0.35	1.20	6.13	
	Long Wall	1	X	2	38.62	0.35	1.20	32.44	
	Pit Composting	1	x	62	5.57	0.15	1.00	51.80	
		1	x	32	1.45	0.15	0.40	2.78	
	125 mm Wall	1	x	32	0.85	0.15	1.00	4.08	
	Office	1	x	6	5.45	0.15	1.20	5.88	
		1	x	1	5.45	0.35	2.70	5.15	
		1	x	1	5.45	0.15	2.70	2.21	
	Toilet	1	x	2	1.80	0.15	2.70	1.46	
		1	x	1	5.45	0.35	2.70	5.15	
		1	x	2	2.62	0.15	2.70	2.12	
	Rainwater Harvesting Pit	2	x	3	0.45	0.15	0.60	0.24	
		2	x	3	0.45	0.15	0.60	0.24	
	Leachate Tank	1	x	1	7.00	0.35	0.08	0.20	
		1	x	1	0.60	0.35	0.23	0.05	
		1	x	1	7.00	0.15	0.23	0.24	
	Deduction Gate	1	x	1	3.00	0.230	2.10	-1.45	
	Column	1	x	34	0.45	0.450	1.80	-12.39	
	Window	1	x	1	1.50	0.230	1.20	-0.41	
	Door	1	x	2	1.00	0.230	2.10	-0.97	
	Toilet Door	1	x	2	0.80	0.230	2.10	-0.77	
							Total	104.18	Cum
7	12 mm thk Internal Plaster in 1:3 with c/s mortar in wall l/c all materials, labour & T&P etc. S.I-586								
	Short Wall	2	X	1	22.00	1.20		52.80	
	Long Wall	2	X	1	38.62	1.20		92.69	
	Pit Composting	2	x	70	5.45	1.00		763.00	
		2	x	50	0.20	0.30		6.00	
		2	x	50	1.00	0.70		70.00	
	125 mm wall	2	x	6	5.45	1.20		78.41	
	Office	2	x	1	5.45	2.90		31.61	
		2	x	1	5.45	2.90		31.61	
	Toilet	2	x	2	1.80	2.90		20.80	
		2	x	1	5.45	2.90		31.61	
		2	x	1	2.62	2.00		10.48	
	Rainwater Harvesting Pit	2	x	4	0.45	2.90		41.76	
	Leachate Tank	2	x	1	7.00	1.00		14.00	
		2	x	1	0.60	1.00		1.20	
		2	x	1	7.00	1.00		14.00	
	Deduction Gate	1	x	1	3.00	0.23		-0.69	

अवर अभियन्ता (निर्माण)  
नगर पालिका परिषद  
मुजफ्फरनगर

सहायक अभियन्ता (निर्माण)  
नगर पालिका परिषद  
मुजफ्फरनगर

	Column	1	x	34	0.45	0.45		-6.89	
	Window	1	344	2	2.00	0.23		-0.92	
	Door	1	x	2	1.50	0.23		-0.69	
	Toilet Door	1	x	2	0.80	0.23		-0.37	
							Total	1250.49	sqm.
8	Providing & laying steelbars including cutting binding, placing and complete in all respect								
		1	X	1	60.00	0.785	1.00	47.10	
							Total	47.10	Qtl
9	M.S. iron Door and window with ms angle and ms sheet l/c all complete as directed by engineer in charge as chapter 10 S.I no 503								
	Gate	1	x	1	3.00	2.100	0.35	2.21	
	Door	1	x	2	0.90	2.000	0.30	1.08	
	Window	1	x	2	1.20	1.200	0.20	0.58	
	Toilet Door	1	x	2	0.60	1.800	0.30	2.16	
							Total	6.02	Qtl
10	Mild steel or iron work in heavy size such as trusses, build up gates record racks, roof work, gates etc wrought to required from including drilling holes riveting or welding where necessary and their fixing required for proper completion of the work.	1	x	1				55.00	Qtl
11	Mild steel or iron work of small size and sections such as holding down bolts, hold fast, tie rods, grating etc,(when not included in an overall rates) wrought to required shape as necessary for bending etc including supply of steel and its wastage including cost of bolts, nuts if required, welding, grinding and making holes as required for completion of work but	1	x	1				12.00	Qtl
12	Providing and fixing precoated galvanised iron sheets (size, shape and pitch of corrugation as approved by Engineer-in-charge) 0.50 mm (+0.05%) total coated thickness with zinc coating 120 grams per sqm as per IS:277, in 240 mpa steel grade, 5-7 microns epoxy primer on both side of the sheet and polyester top coat 15-18 microns. Sheet should have protective guard film of 25 microns minimum to avoid scratches during transportation and should be supplied in single length upto 12 metre or as desired by Engineer-in-charge. The sheet shall be fixed using self drilling metre or as desired by Engineer-in-charge. The sheet shall be fixed using self drilling/self tapping screws of size (55x55mm) with EPDM seal, complete upto any pitch in horizontal/vertical or curved surfaces, excluding the cost of purlins, rafters and trusses and including cutting to size and shape wherever required	1	x	1	15.00	48.000		720.00	Sqm
13	Supply & fixing 5 mm thick approved China white/coloured glazed tiles in flooring or dado laid with 1:3 comont and approved coarse sand mortar finished and jointed with white cement slurry and pigment & polishing complete including supply of all materials, labour and T&P etc. required for proper completion of the work. (size of tiles upto 300 x 300 mm)	1	x	1	4.43	5.445		24.12	Sqm

अवर अभियन्ता (निर्माण)  
नगर पालिका परिषद  
मुजफ्फरनगर

सहायक अभियन्ता (निर्माण)  
नगर पालिका परिषद  
मुजफ्फरनगर

		345							
14	Supply & fixing 5-10 mm thick approved China white/coloured glazed tiles in flooring or dado laid with 1:3 cement and approved coarse sand mortar finished and jointed with white cement slurry and pigment & polishing complete including supply of all materials, labour and T&P etc. required for proper completion of the work. (size of tiles upto 300 x 300 mm)	1	x	2	2.70	1.800		9.72	Sqm
15	Distemping(First coat) with oil bound distemper of approved brand and manufacture and of required shade on undecorated wall surface to give an even shade over and including a priming coat with cement primer of approved brand and manufacture such as Berger, J & N Shallmar, Asian Paints after thoroughly brushing the surface free from mortar dropping and other foreign matter and also including preparing the surface even with Plaster of Paris or approved approved synthetic synthetic material and sand papered smooth including cost of all materials.	1	x	1		1250.49		1250.49	Sqm
16	Painting of wood or iron work including sand preparing rubbing and cleaning as required for proper completion of work (two coats)								
		1	x	4	0.90	1.950		7.02	
		1	x	4	1.20	0.900		4.32	
		1	x	1	47.95	14.600		700.07	
							Total	711.41	Sqm
17	Painting or Varnishing on iron works in small areas or new wood work with one coat of ready mixed priming paint & one coat of approved superior quality ready mixed paint of clear synthetic varnish including supply of all materials, labour and t&P etc. required for proper completion of the work paint to be used should confirm to the I.S.I No. 107								
		1	x	1	3.00	2.10	0.30	6.30	
							Total	6.30	Cum
18	Providing and applying putty of 2mm thickness over plastered surface to prepare the surface even and smooth complete								
		1	x	1				1.00	
							Total	1.00	Each
19	Supply and fixing 32mm thick flush door all complete fitting								
		1	x	2	0.90	1.80		3.24	
							Total	3.24	Sqm
20	Supply and fixing aluminium flush door all complete fitting bathroom and Latrin 32mm thick flush door all complete fitting								
		1	x	2				2.00	
							Total	2.00	Each
21	Supply and fixing 32 mm thick flush door ply wood with handle fitting all complete								
		1	x	32	1.00	1.00		32.00	
							Total	32.00	Sqm
22	Wiring point for light with 1.5 sq. mm. PVC insulated single core aluminium conductor cable in heavy gauge rigid steel conduit pipe on surface, complete with 8 SWG GI earth continuity wire, plano type switch and ceiling rose/angle batten holder on 3 mm. thick phenolic laminated backelite-sheet etc. complete in all respect. as								
		1	x	22				22.00	Each

अवर अभियन्ता (निर्माण)  
नगर पालिका परिषद

सहायक अभियन्ता (निर्माण)  
नगर पालिका परिषद  
गुजपफरमगर

38	Supply and fixing of 150 mm dia Top Cap	1	346	1				1.00		
								Total	1.00	Each
39	Supply and fixing of 150 mm dia Centerlizer	1	x	1				1.00		
								Total	1.00	Each
40	P/F 550X400mm hand wash basin of white glazed earthen ware ISI marked (Hindustan neyer cera make ) i/c supply of all materials labour and I&O comm.	1	x	1	-	-	-	1.00	Nos.	
41	P/F flat back 465 mm x 355 mm x 265 mm size tipped from uninal basin of white glazed earthen ware first quality (Hindustan Nycer	1	x	1	-	-	-	1.00	Nos.	
42	P/F polyvinyl chloride (CPVC) pipe 20mm dia	1	x	1	10	-	-	10.00	Mtr.	
43	P/F polyvinyl chloride (CPVC) pipe 15mm dia	1	x	1	25	-	-	25.00	Mtr.	
44	P/F bib brass bib cock 400 gms i/c all	1	x	1	8	-	-	8.00	Nos.	
45	Making water connoction of GI pipe line with GI main as in SI 210	1	x	1	-	-	-	1.00	Nos.	
46	PVC low level cisterns 10 ltr capacity with all internal fittings of PVC etc.	1	x	1	-	-	-	1.00	Nos.	
47	Handpump with submercioble	1	x	1				1.00	Nos.	

35

अवर अभियन्ता (निर्माण)  
नगर पालिका परिषद

सहायक अभियन्ता (निर्माण)  
नगर पालिका परिषद  
मुजफ्फरमगर

**347**  
(Handpump with submerciable)

36

S	Item	Qty.	Unit	Rate	Amount
1	2	3	4	5	6
1	Shifting of handpump set complete and releated material jainigam store to work site	1.00	No.	1,350.00	1,350.00
2	Cost of essential material for handpump installation work				
3	A. Handpump machine set complete	1.00	set	5,600.00	5,600.00
4	B. P.V.C. pipe (6kg/sqcm) 110mm dia	60.00	Rm	280.00	16,800.00
5	C. G.I. pipe 32mm dia medium quality (riser)	42.00	Rm	195.63	8,216.46
6	Rent of boring T&P and excavation of pit, ghaat etc set work for drilling work by pump and pressure method	1.00	Rm	850.00	850.00
7	Drilling work 150mm dia in hard and conker mix soil by pump and pressure method				
8	A. 0-30m	30.00	Rm	320.00	9,600.00
9	B. 30-45m	15.00	Rm	360.00	5,400.00
10	C. 45-60m	15.00	Rm	480.00	7,200.00
11	P.V.C. assembly in which loring P.V.C. pipe and strainer of 110mm dia blind pipe strainer				
12	A. 0-30m	30.00	Rm	15.00	450.00
13	B. 30-45m	15.00	Rm	18.00	270.00
14	C. 45-60m	15.00	Rm	18.00	270.00
15	A. Suply/Pouring of coarse sand arround strainer in drilling i/c all	1.00	job	175.00	175.00
16	B. Filling work of betonite in between housing pipe and bore hole	1.00	job	550.00	550.00
17	Installation of handpump india marka-2 including with riser	1.00	No.	535.00	535.00
18	Development work till satisfaction of engineer incharge after installation of handpump	1.00	job	165.00	165.00
19	Disinfection work with material after development work	1.00	job	80.00	80.00
20	Construction of handpump platform of 1.85m dia including all material, labour T&P etc as per I.S.S. sanction design	1.00	No.	5120.00	5,120.00
21	Construction of drain including all material, labour T&P etc	3.00	Rm	240.00	720.00
22	Imboing and painting work	1.00	job	80.00	80.00
23	Water test work	1.00	job	650.00	650.00
24	Solvent & jointing kit	1.00	job	1,000.00	1,000.00
25	Supply & fixing of summersebile pump (krloshkar made) hp.	1.00	No.	14750.00	14,750.00
26	Supply of controte panne or summersebile pump	1.00	No.	2600.00	2,600.00
27	Supply of summersebile fiate cable 1.5 square. mm 3 core copper	80.00	Rm	50.00	4,000.00
				Total	86431.46

  
अवर अभियन्ता (निर्माण)  
नगर पालिका परिषद  
मुजफ्फरनगर

  
सहायक अभियन्ता (निर्माण)  
नगर पालिका परिषद  
मुजफ्फरनगर

37

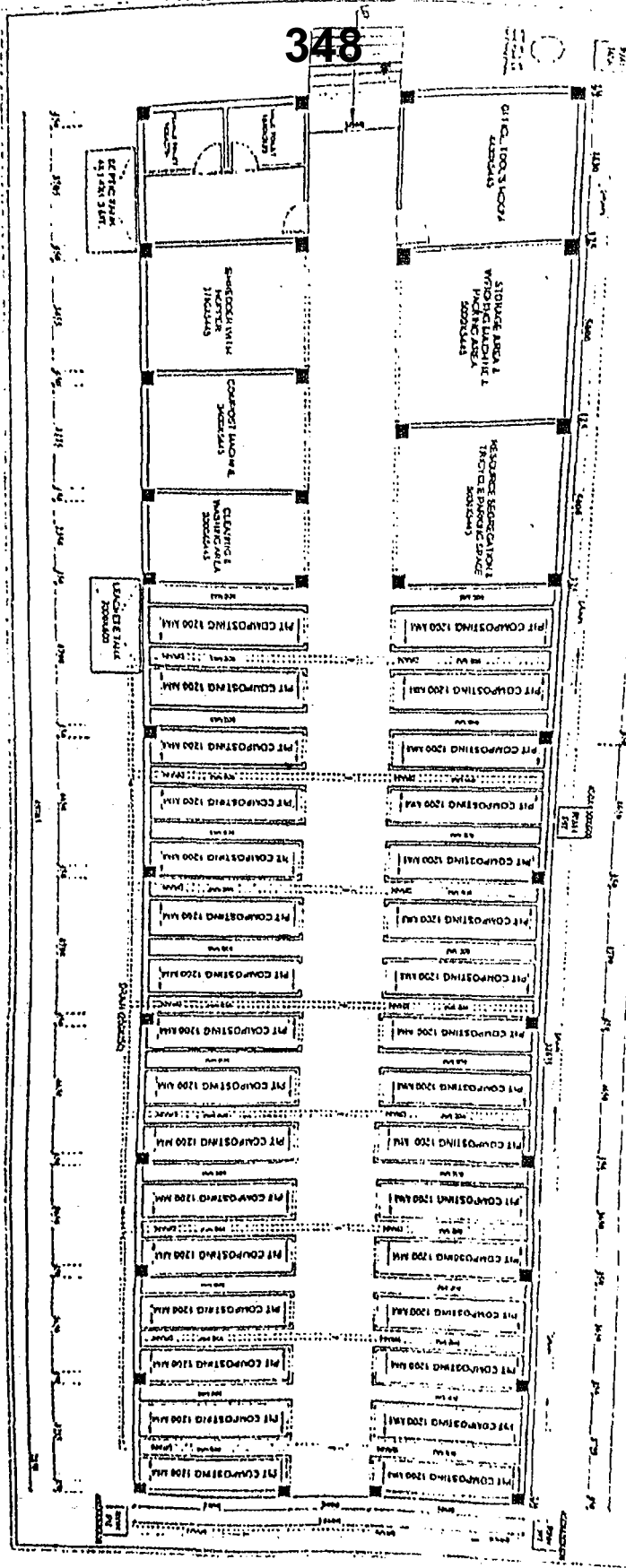

WET WASTE PROCESSING UNIT  
 TOTAL CAPACITY = 5 TONS  
 TOTAL AREA REQUIRED = 700 SQ.MT.

अवर अभियन्ता (निर्माण)  
 नगर पालिका परिषद  
 मुजाफ्फरनगर

सहायक अभियन्ता (निर्माण)  
 नगर पालिका परिषद  
 मुजाफ्फरनगर

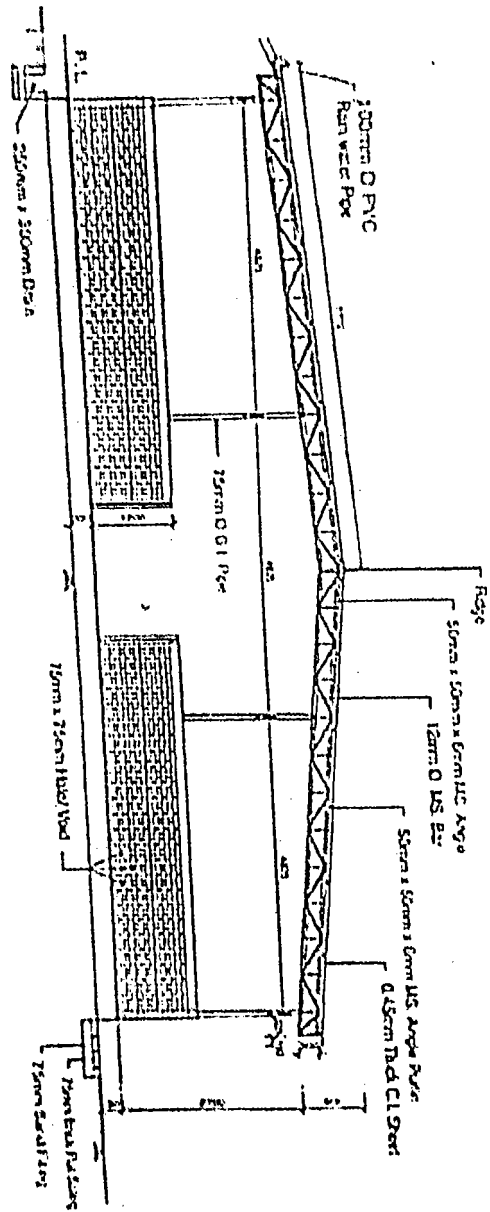

Wet Waste Processing Unit Cross Section View

  
 अवतर अभियन्ता (निर्माण)  
 नगर पालिका परिषद  
 मुजाफरनगर

  
 सहायक अभियन्ता (निर्माण)  
 नगर पालिका परिषद  
 मुजाफरनगर

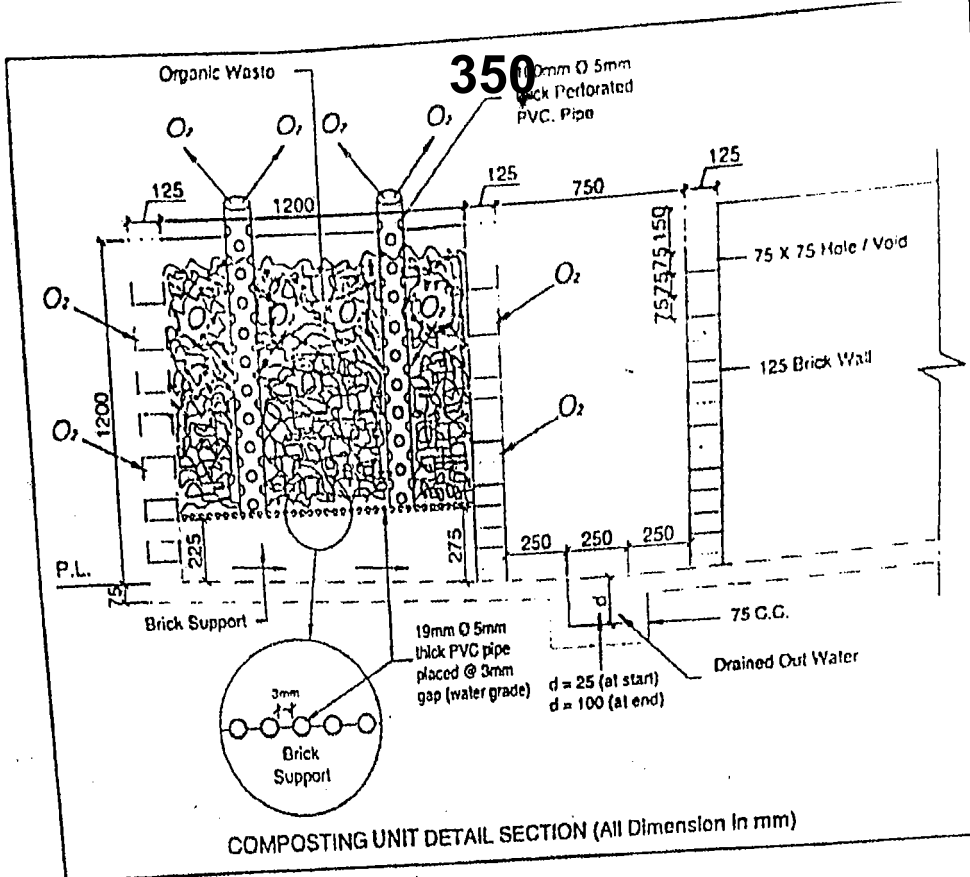

Drainage channels (layout plan) and dimensions of vertical pipes (right)

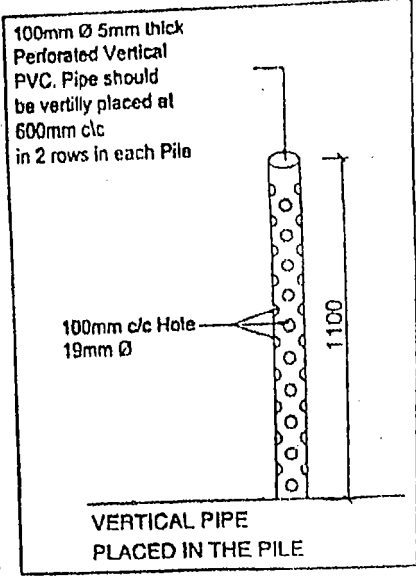
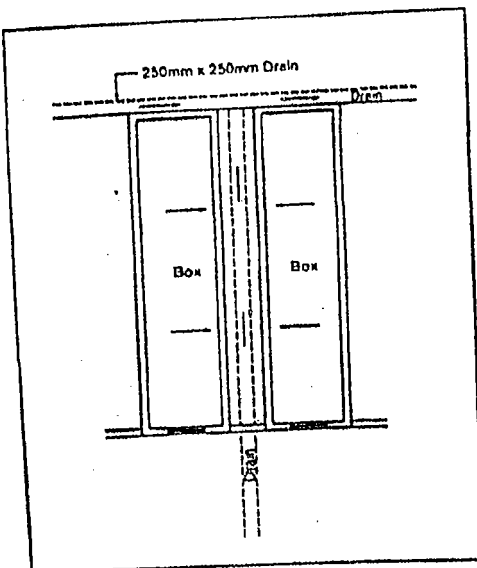

अचर अभियन्ता (निर्माण)  
 नगर पालिका परिषद  
 मुजफ्फरनगर

सहायक अभियन्ता (निर्माण)  
 नगर पालिका परिषद  
 मुजफ्फरनगर

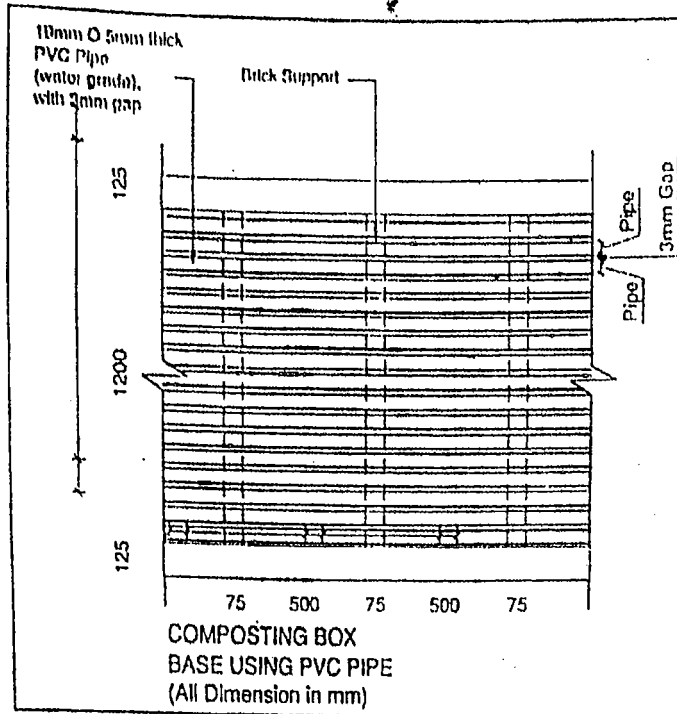

Bottom level drainage grid construction with MS rod grid (birds view)

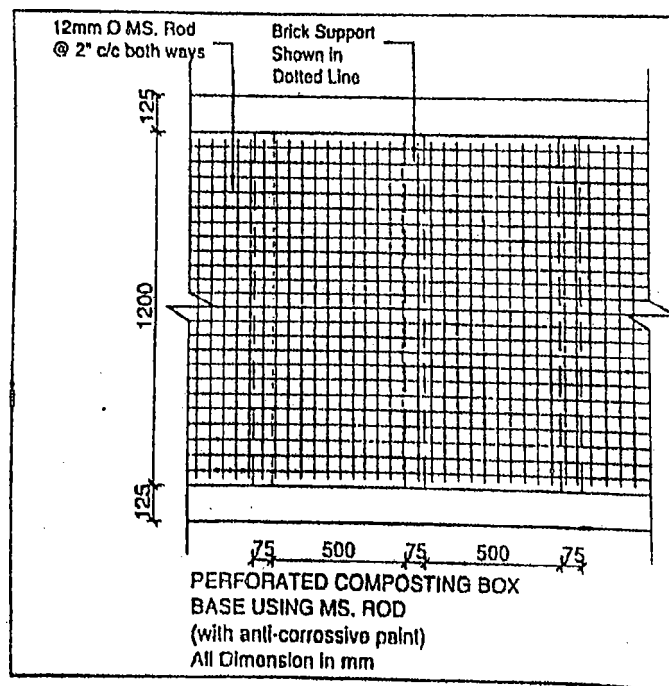



अवर अभियन्ता (निर्माण)  
नगर पालिका परिषद  
मुजफ्फरनगर

सहायक अभियन्ता (निर्माण)  
नगर पालिका परिषद  
मुजफ्फरनगर

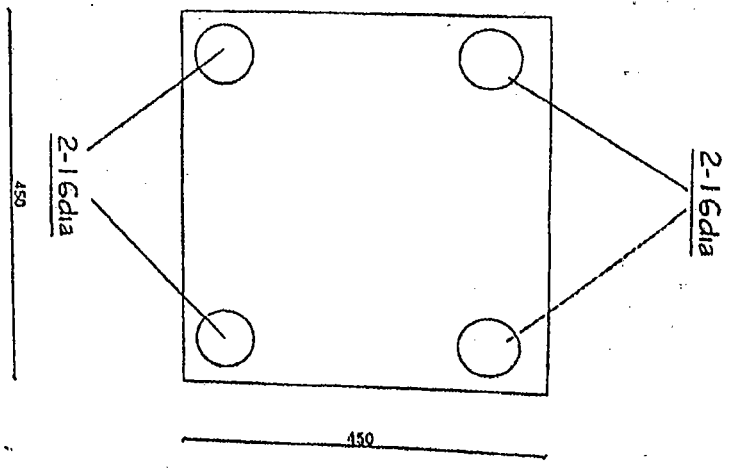
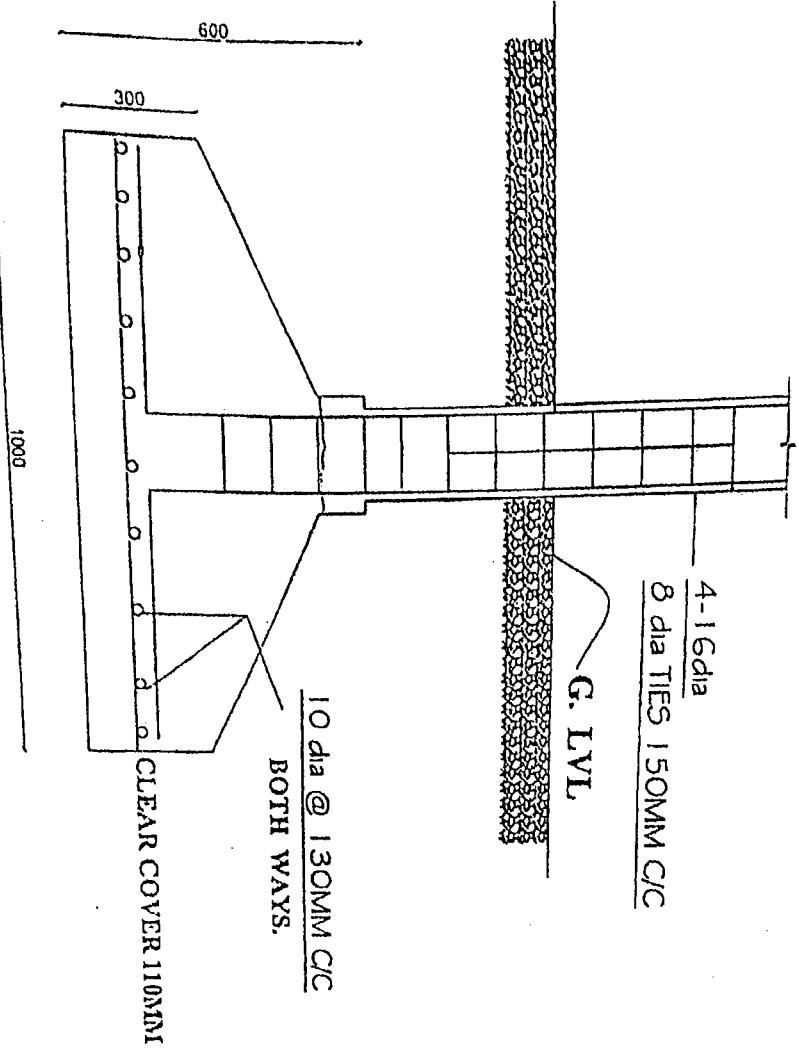
17



  
 संरचना अभियंता (निर्माण)  
 म. प्र. शा. २०१८  
 मुंबई

  
 संरचना अभियंता (निर्माण)  
 म. प्र. शा. २०१८  
 मुंबई



INDIA NON JUDICIAL  
353  
Government of Uttar Pradesh

ANNEXURE A 7

e-Stamp

42

Certificate No.	: IN-UP89408971469249V
Certificate Issued Date	: 20-Apr-2023 10:42 AM
Account Reference	: NEWIMPACC (SV)/ up14137904/ MUZAFFARNAGAR/ UP-MJF
Unique Doc. Reference	: SUBIN-UPUP1413790473206087274181V
Purchased by	: ET DCC JV
Description of Document	: Article 5 Agreement or Memorandum of an agreement
Property Description	: Not Applicable
Consideration Price (Rs.)	:
First Party	: ET DCC JV
Second Party	: SILVERTON PAPERS LIMITED
Stamp Duty Paid By	: ET DCC JV
Stamp Duty Amount(Rs.)	: 100 (One Hundred only)

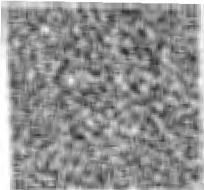
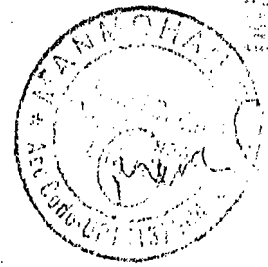

Please write or type below this line

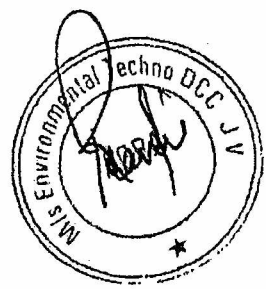

For SILVERTON PAPER  
*[Signature]*

43

**Agreement**

For management of Refuse Derived fuel (R.D.F.)/ Multilayer Paper (M.L.P.) generated in processing of Biomining work.

**Between**

**FIRST PARTY:** Environmental Techno having its registered office at G-7, Shanti Niketan, Church Road, Agra, Uttar Pradesh- 282006.

**And**

**SECOND PARTY:** Silvertan Papers Limited having its registered office at 9 K.M. Bhopa road, Muzaffarnagar, Uttar Pradesh- 251308

This agreement is made and entered into this 20 day of April 2023 and between

**FIRST PARTY:** Which has contract for processing of Legacy waste from Uttar Pradesh Jal Nigam at Prempuri, Near Machli talab, Kidwai Nagar, Muzaffarnagar, Uttar Pradesh.

**SECOND PARTY:** Is in Papermaking business and its consumer of R.D.F./ M.L.P. and has necessary permissions to consume said materials.

**WHEREAS**

**FIRST PARTY:** Environmental Techno is responsible for processing legacy waste within its jurisdiction. During processing reasonable quantity of non-recyclable fraction containing cloths, plastics and other combustible material called refuse Derived Fuel (R.D.F.)/ M.L.P. is generated.

**And WHEREAS**

**SECOND PARTY** is in business of Paper Manufacturing and has a capacity to dispose R.D.F./M.L.P. in an environmentally friendly manner. This material will be used as fuel in a Boiler Furnace having sufficient temperature and residence time to burn R.D.F./M.L.P. and will meet the emission norms.

For SILVERTAN PAPERS LTD.

  
Director



44

Now therefore, to ensure the safe disposal of R.D.F./M.L.P. segregated from legacy waste above parties have entered into agreement.

**Validity of agreement:**

This agreement shall be valid for a period of one year from the date of signing and execution of this agreement

**Responsibility of Parties:**

1) Responsibility of First Party

- a) To supply RDF/MLP generated in processing Biomining waste to Second Party.
- b) To make sufficient quantity of R.D.F./ M.L.P. available at site for SECOND PARTY.

2) Responsibility of SECOND PARTY

- a) To accept and utilize delivered quantity in an environmentally friendly manner.
- b) SECOND PARTY will issue a disposal certificate to FIRST PARTY in the first week of the every month of quantity of R.D.F./M.L.P. received during the last month.

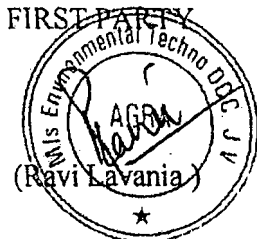

SECOND PARTY  
 For SILVERTON PAPERS LTD  
  
 (Amit Garg) Director

WITNESS:

(Signature)

DHRUV MAHESHWARI  
 # 895450007  
 87B, New Mandi,  
 Morzaffarnagar (U.P.)



(Signature)

Neeraj Jain  
 245702-245702  
 Morzaffarnagar

356







## कार्यालय नगरपालिका परिषद्, मुजफ्फरनगर

पत्रांक 1443 / सा0प्र0 / 2023-24

दिनांक : 5-10-2023

## ई-निविदा सूचना

नगर पालिका परिषद्, मुजफ्फरनगर द्वारा किदवईनगर स्थित कूड़ा प्रोसेसिंग प्लान्ट के कूड़े के प्रसंस्करण, निपटान एवं निष्कासन किये जाने के सम्बन्ध में ई-निविदाए दिनांक 20.10.2023 को अपराह्न 3:00 बजे तक आमन्त्रित की जाती है। वेबसाईट <https://etender.up.nic.in> पर निविदा फार्म ऑनलाईन दिनांक 06.10.2023 की प्रातः 10:00 के बाद से दिनांक 06.10.2023 की सायं 3:00 बजे तक डाउनलोड तथा अपलोड की जा सकती है। कार्य की धरोहर राशि एफ0डी0आर0/एन0एस0सी0 आदि के रूप में जो अधिशासी अधिकारी नगर पालिका परिषद्, मुजफ्फरनगर के नाम बन्धक होगी, तथा निविदा मूल्य (जी0एस0टी0 सम्मिलित करते हुए) का ड्राफ्ट नगर पालिका परिषद्, मुजफ्फरनगर के पक्ष में जारी करते हुए निविदा खोले जाने के उपरान्त मूल प्रति के रूप में कार्यालय को उपलब्ध कराया जाना अनिवार्य है। अन्य विवरण एवं शर्तें किसी भी कार्य दिवस में स्वास्थ्य विभाग कार्यालय में आकर अवलोकन कर सकते हैं। प्राप्त निविदाओं को दिनांक 20.10.2023 को सायं 4:00 बजे अधिशासी अधिकारी के कार्यालय में खोली जायेगी तथा निविदा खाले जाने वाली दिनांक को सार्वजनिक अवकाश एवं विषम स्थिति उत्पन्न होने की दशा में निविदा अगले कार्यदिवस में सायं 4:00 बजे खोली जायेगी। अधिक जानकारी के लिए ऊपर दी गयी वेबसाईट पर लॉगइन कर सकते हैं। सशर्त कोई भी निविदा मान्य नहीं होगी।

क्र0 सं0	कार्य का नाम	व्ययानुमान की धनराशि	10 प्रतिशत धरोहर राशि	निविदा मूल्य 18 प्रतिशत जी0एस0टी0 सहित	कार्य पूर्ण अवधि
1.	किदवईनगर स्थित कूड़ा प्रोसेसिंग प्लान्ट के 5 लाख मीट्रिक टन कूड़े के प्रसंस्करण, निपटान एवं निष्कासन किये जाने के सम्बन्ध में	17,50,00,000/-	1,75,00,000/-	87,550+15,759=1,03,309/-	12 माह

नोट:-जो अनुभवी फर्म/कम्पनी ई-निविदा में भाग लेना चाहते हैं, वह अपना ऑनलाईन पंजीकरण वेबसाईट <https://etender.up.nic.in> पर अनिवार्य रूप से करा ले।

नगर स्वास्थ्य अधिकारी  
नगर पालिका परिषद्  
मुजफ्फरनगर

अधिशासी अधिकारी  
नगर पालिका परिषद्  
मुजफ्फरनगर

Meenakshi  
अध्यक्ष  
नगरपालिका परिषद्  
मुजफ्फरनगर।

नगर पालिका परिषद्, मुजफ्फरनगर

Ede, the Netherlands, 9<sup>th</sup> of June 2024

To: Executive Officer of Muzaffarnagar Nagar  
Mrs. Pragya Singh  
Muzaffarnagar Nagar Palika

Dear Madam,

This letter is to confirm our commitment to start with clearing the landfill of Muzaffarnagar, also known as the Muzaffarnagar Recycle facility, by the second part of this year, 2024. We will do this step by step and are aiming to clear at least 60,000 m<sup>3</sup> of waste by the end of this year (A+B). The waste will be separated into RDF, sand, soil and stones, as well as other materials that can be recycled later on in time, when we have the full Waste to Energy plant available. Our focus will not only be fresh waste, we also focus on legacy waste in the first phase of the project.

In 2024 we are shipping a separation installation to Muzaffarnagar that has a capacity of maximum 1,000 tpd of waste. This is a mobile installation and will become operational in the 2<sup>nd</sup> part of 2024. The sand and stones we separate from the waste we will use for leveling our plots or for concrete production. The waste to energy plant of Muzaffarnagar can handle both fresh waste and legacy waste.

We will process the fresh waste and legacy waste at no cost.

This is only possible when the site has an easy access for larger transport trucks. To remove waste via the existing town streets and alleys will be difficult. We are hoping that the temporary access roads will become available at the start next of this year. We will need a good road to bring in equipment and to move material to clients. Via existing roads through town that will be difficult.

More important is the progress of the main approach road for which a new road and bridge are needed. We are seeing progress with the construction of the bridge. We can only speed up when this new connection is ready. We hope you understand this.

End of June I am visiting Muzaffarnagar again. I hope we can meet and make a more detailed plan for the months to come.

Warm regards,

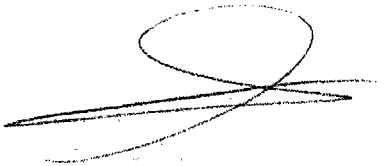

Therus Gieling, CEO of GCIND Solutions Pvt. Ltd.



ANNEXURE A-13

कार्यालय नगर पालिका परिषद, मुजफ्फरनगर

बोर्ड बैठक दिनांक 20.07.2024 प्रस्ताव संख्या: 337

रिपोर्ट स्वास्थ्य विभाग बाबत नगर पालिका परिषद, मुजफ्फरनगर क्षेत्र में वेस्ट टू एनर्जी प्लांट लगाये जाने हेतु GCIND Solution Pvt.Ltd. एवं तत्कालीन अधिशासी अधिकारी, नगर पालिका परिषद मुजफ्फरनगर के मध्य लीज डीड दिनांक 19.10.2023 में साईन की गयी। किदवईनगर, मुजफ्फरनगर स्थित प्लांट पर लिगेसी वेस्ट अत्याधिक मात्रा में उपलब्ध है। उक्त लिगेसी वेस्ट के प्रोसेसिंग कर निस्तारण किये जाने हेतु GCIND Solution Pvt.Ltd. के उच्चाधिकारियों से दिनांक 13.03.2024 में वार्ता की गयी जिसमें उनके द्वारा अवगत कराया गया कि फर्म प्लांट पर उपलब्ध कुल लिगेसी वेस्ट का निशुल्क प्रोसेसिंग कर निस्तारण करने के लिये तैयार हैं जिसके लिये उक्त फर्म ने दिनांक दिनांक-05.06.2024 और 09.06.2024 में पत्र प्रेषित किये हैं।

सम्बन्धित फर्म GCIND Solution Pvt.Ltd. द्वारा किदवईनगर, मुजफ्फरनगर में स्थित प्लांट पर उपलब्ध कुल लिगेसी वेस्ट का निशुल्क प्रोसेसिंग कर निस्तारण कराये जाने की बोर्ड स्वीकृति हेतु मा० अध्यक्ष महोदया द्वारा विषय बोर्ड के समक्ष प्रस्तुत किये जाने के लिये दिनांक 12.07.2024 में आदेश प्रदान किये गये हैं।

अतः उपरोक्त विषय बोर्ड के समक्ष विचारार्थ एवं स्वीकृतार्थ प्रस्तुत है।  
प्रस्ताव प्रस्तुत होने पर सदन द्वारा सर्वसम्मति से पारित किया गया।

शुद्ध प्रतिलिपि

  
कार्यालय अधीक्षक

Ede, the Netherlands, 13<sup>th</sup> of June 2024

To: Executive Officer of Muzaffarnagar Nagar  
Mrs. Pragya Singh  
Muzaffarnagar Nagar Palika

Subject: Proposal for Processing of legacy waste at Muzaffarnagar land fill situated at GCIND Pvt Ltd allotted waste to energy plant site.

Dear Mrs Pragya Singh,

We, GCIND Solutions Pvt. Ltd. are proposing to start the works of setting up a complete Waste to Energy plant in Muzaffarnagar, producing approximately 30 MW of electricity and by-products out of recycled waste flows.

This Project is a part of the original concept of GC International, which is the Waste to Wealth program from 2018-2019 which aims to clean up legacy waste and fresh MSW lying at dumpsites and landfills. The project location of the Muzaffarnagar waste to energy facility, consists of a landfill and an adjacent land parcel on which the waste to energy plant is proposed to be built. The landfill is containing at least 460,000 m<sup>3</sup> of legacy waste and, on the adjacent plot that is part of the land leased by GCIND Solutions, a further 120,000 m<sup>3</sup> of waste is expected to be present. In total around an estimate 580,000 m<sup>3</sup> of legacy waste is expected to be present on the land parcel .

#### **Reading guide to this letter**

In this letter we will first focus on the phases of construction. It explains what will happen. The second part of the letter will focus on the waste management of the project from this point onwards through the various phases of the project. We put on the waste flows itself, what arrives at our land and what do we need to ship away. Also we will include a plan where to dump incoming waste and where we will process it.

As you have been informed, we have split the project in two phases:

#### **Phase 1: Focus on preparing the plot for the construction of the Waste to Energy plant**

- Start: by the end of August – beginning September 2024 – crucial that temporary access road is accessible
- Goal: To start remediation works on landfill site and adjacent plot and to prepare all the further works for construction of large waste to energy plant.

**In short:** Although activities for phase 1 have started, we will begin on site with clearing and processing of legacy waste into RDF in the first parts of the landfill as well as the adjacent plot (in total at least 180,000 m<sup>2</sup> of waste). This clearing enables us to start with preparatory works for the final phase 2, which is the construction of the entire waste to energy plant. In phase 1 preparatory construction works include the construction of a collection platform, a bio digester, a water treatment plant for the entire complex and office building all to be put at the landfill plot.

See the steps here below:

- Clearing of large part of landfill by establishment of a mobile Waste Separation unit/ RDF manufacturing facility.
  - For enabling us to clear the landfill it would be great if the set up of machinery at the sight as it was until May of this year would be restored. In other words, **please bring back the cranes that helped to move the waste on the site. Would this be possible?**
  - We will begin by clearing at least 60,000 M<sup>3</sup> of waste from the landfill, see figure 1 here below.
  - and will subsequently move towards clearing 120,000 M<sup>3</sup> of waste in the adjacent land parcel (Part C + D see Figure 1 here below).

Figure 1

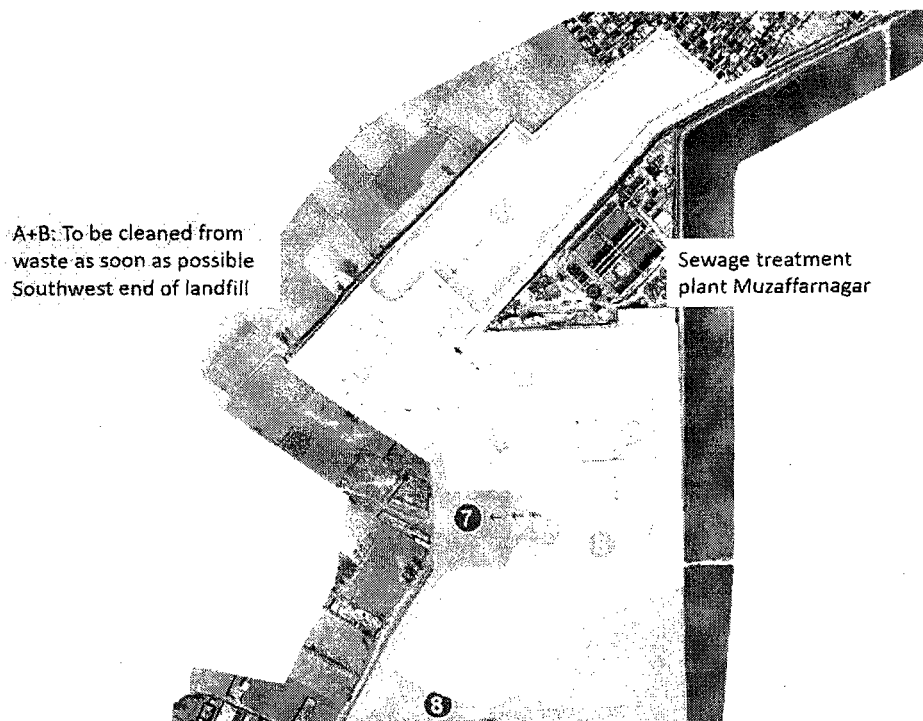

- The Legacy waste will be processed by GIND Solution Pvt, Ltd **at no cost** to the Muzaffarnagar municipality.
- Waste (mainly legacy waste) will be separated in various resources:
  - sand and stones will be filtered out and set apart for later use – leveling of the land (we will be needing a lot of sand and stones for construction of the plant)
  - RDF: RDF is the type of waste material that can be used for production of energy - electricity. We will be processing the waste and manufacture it into RDF
  - Some materials might be sold to make space for needed construction works.
- Making space on the landfill parcel for first security and office building, a collection platform (30 x 60 m) as well as the construction of high tech **300 TPD- Bio Digester** for generation of 2 MW of power for captive use during construction phase of waste to energy plant – Aim is to start making space (first section A – figure 1) in July 2024 by moving the waste. **Separation works will start in October 2024 with a maximum capacity of 1,000 tpd.**

- Part of the Bio Digester is a **large water treatment plant** with ample capacity to clean leakage water coming from the entire Waste to Energy campus.
- Engineering and planning rest project into detail: EIA trajectory kick start, setting up larger project team based in India
- As soon as part A + B are entire cleared from waste construction of the above mentioned works will take place. The mobile separation unit then moves to the adjacent plot to clean **a further 120,000 m3 of waste** (South of the existing sewage treatment plant). This will again be done at a pace of maximum 1,000 tpd.

At the end of phase 1 approximately 180,000 m3 of waste is cleared from the landfill and adjacent plot. A bio digester and water treatment plant are operational (Q2-Q3 2025). A collection platform receives the daily incoming waste. The further projected 400,000 m3 of waste will be cleared when the waste to energy plant is in full operation. The current landfill/ Muzaffarnagar recycle facility will become a functioning recycle facility again due to clearance of the legacy waste.

**Where to dump the waste**

It is important that the landfill becomes a compact landfill, where waste is stored on a much smaller piece of land than that waste is now dumped in the current situation. **Only when we agree on this point we can achieve the steps in Phase 1 in the pace as we have mentioned here above.** We propose that you dump the waste in **section E of Figure 1** until the collection platform is operational (expected Q4 2024). Please see Figure 2 here below for the route for dump trucks.

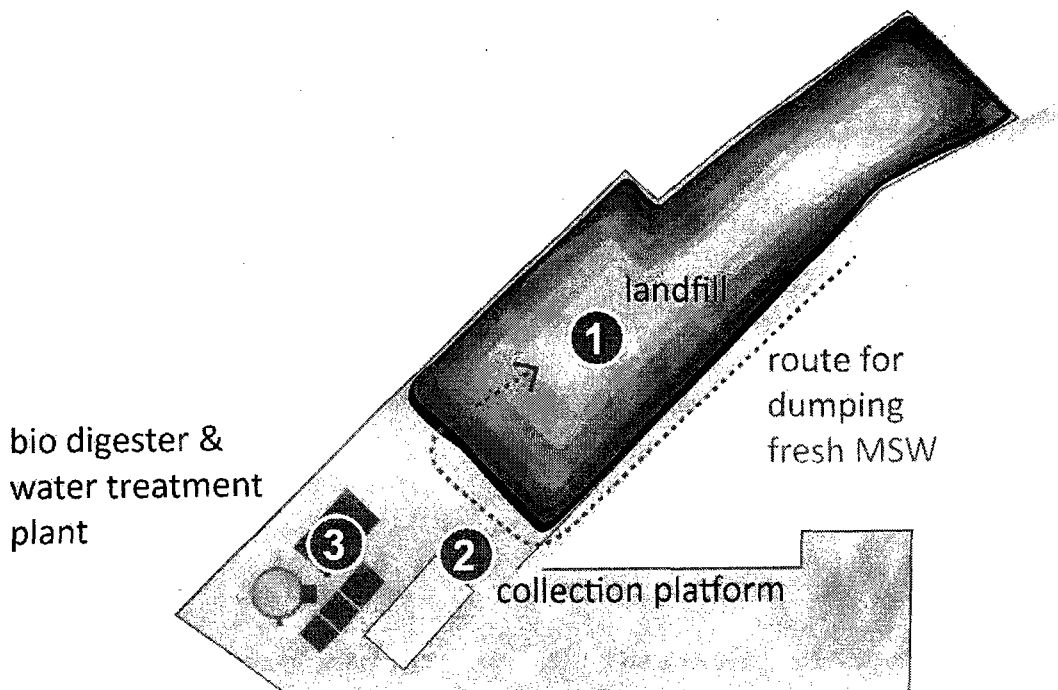

Figure 2: please see for **blue line** indicating the route for dumping waste

**Phase 2: Construction of the final Waste to Energy plant campus**

- Construction of Waste to energy plant including:
  - Separation unit with max capacity of 2,000 TPD solid waste
  - Storage halls for RDF and recyclables
  - Waste to Energy plant that will generate approximately 30 MW of power
  - Concrete block production facility for the re-use of slacks
  - Office complexes including quarters for staffers,
- The plant will be based on the latest technology adhering to EU/Global standards and the technology will also fully comply with Indian standards. The waste separation will be fully automated to wherever possible to achieve the highest calorific value for further processing. We will use the first phase for testing various separation technologies to be able to build the most efficient separation unit in phase 2.
- The Incineration technology will be the latest technology adhering to EU/Global standards and the technology will also fully comply with Indian Central/State Government pollution control norms and standards.
- That includes technologies that make sure lowest possible emission standards are being reached (No leakage, air is filtered completely, waste processing mainly indoors)

**About the delivery of waste to Muzaffarnagar Waste to Value facility by government bodies:**

Please consider this section of the letter as a first suggestion to set up an agreement between GCIND Solutions Pvt Ltd and the Municipality of Muzaffarnagar in which we both further detail the agreement we already have with UP Government in regard to the supply of waste by ULB's of the districts of Saharanpur Division. The Municipal Waste Supply agreement could be drafted based on three stages in which the waste to energy plant is coming into operation:

**Current Situation – start Phase 1**

While the construction of the waste to energy plant is ongoing we are able to receive the daily amount of waste as is being brought to the landfill currently. We do want to understand how much waste is being brought to the landfill currently. This is to be able to plan the entire waste management operation. We also would like you to bring all daily produced MSW to the landfill since our processing capacity will be in place as we have stated here above. Next to that we would like to see the crane back on the landfill (see above, page 2)

- Could you give us an indication of the amount of waste that is being brought daily?

**End of Phase 1**

When the bio digester is constructed we are able to receive **extra organic waste up to 300 tpd**. This can be manure or other organics, such as the wet municipal solid waste. The time lines are depending on the opening date of the major approach road and bridge.

- We expect to receive this type of waste 4 months after the opening date of the main approach road. This is extra waste, on top of the daily amount of MSW.

**End of Phase 2**

When the entire factory is constructed – this will take a few more years to complete – we are capable of receiving 1,750 tpd of fresh MSW at our plant. We also process legacy waste by then, from our landfill or other landfills. With the Department of Urban Development we have agreed that all the ULB clusters within in Saharanpur Division will bring their waste to our Waste to Energy plant. Please see the registered “Support Agreement Muzaffarnagar Waste to Value Project of October 14<sup>th</sup> 2019”, page 2 clause 2. We will provide a working solution for the entire Saharanpur Division.

- When the waste to energy plant is fully operational we, GCIND Solutions Pvt. Ltd., will be receiving 1,750 tpd of MSW from the ULB Custer within Saharanpur Division as per the agreement made with the Government of Uttar Pradesh.

I hope this letter gives you a clear insight into our waste to energy project, gives you the certainty that we will start with remediation of the landfill, and assures you that you will keep a secure place to bring your fresh MSW on a daily basis. Timelines given in this letter are dependent on factors such as accessibility to our plot. We do see great progress in the construction of the bridge. We have good hopes the temporary access road is in place soon. Also we hope to sign a waste supply agreement with the municipality of Muzaffarnagar soon.

Warm regards,

Mr. Therus Gieling, CEO of GCIND Solutions Pvt. Ltd

(56)  
कार्यालय नगरपालिका 367 परिषद, मुजफ्फरनगर

ANNEXURE A-

पत्रांक : 108 / सा0प्र0 / 2024-25

दिनांक : 22-06-2024

ई-निविदा सूचना

नगर पालिका परिषद, मुजफ्फरनगर द्वारा किदवईनगर स्थित कूड़ा निस्तारण प्लान्ट पर प्रतिदिन आने वाले फ्रैश वेस्ट के प्रसंस्करण, निपटान एवं निष्कासन अनुभवी फर्म/कम्पनी/ठेकेदार से कार्य कराये जाने हेतु ई-निविदाए दिनांक 13-07-24 को अपराह्न 3:00 बजे तक आमन्त्रित की जाती है। वेबसाईट <https://etender.up.nic.in> पर निविदा फार्म ऑनलाईन दिनांक 24-06-24 की प्रातः 10:00 के बाद से दिनांक 13-07-24 की सायं 3:00 बजे तक डाउनलोड तथा अपलोड किये जा सकते हैं, साथ ही निविदादाता को स्वघोषणा पत्र देना अनिवार्य होगा यह स्वघोषणा पत्र अंकन-100/-रु0 के स्टाम्प पेपर पर नोटरी द्वारा सत्यापित होना आवश्यक है। कार्य की धरोहर राशि एफ0डी0आर0/एन0एस0सी0 आदि के रूप में जो अधिशासी अधिकारी नगर पालिका परिषद, मुजफ्फरनगर के नाम बन्धक होगी, तथा निविदा मूल्य (जी0एस0टी0 सम्मिलित करते हुए) का ड्राफ्ट नगर पालिका परिषद, मुजफ्फरनगर के पक्ष में जारी करते हुए निविदा खोले जाने से पूर्व मूल प्रति के रूप में कार्यालय को उपलब्ध कराया जाना अनिवार्य हैं। अन्य विवरण एवं शर्तें किसी भी कार्य दिवस में स्वास्थ्य विभाग कार्यालय में आकर अवलोकन कर सकते हैं। प्राप्त निविदाओं को दिनांक 13-07-24 को सायं 4:00 बजे अधिशासी अधिकारी के कार्यालय में खोली जायेगी तथा निविदा खोले जाने वाली दिनांक को सार्वजनिक अवकाश एवं विषम स्थिति उत्पन्न होने की दशा में निविदा अगले कार्यदिवस में सायं 4:00 बजे खोली जायेगी। अधिक जानकारी के लिए ऊपर दी गयी वेबसाईट पर लॉगइन कर सकते हैं।

क्र0 सं0	कार्य का नाम	व्ययानुमान की धनराशि मय जी0एस0टी0	10 प्रतिशत धरोहर राशि	निविदा मूल्य 18 प्रतिशत जी0एस0टी0 सहित	कार्य पूर्ण अवधि
1	किदवईनगर स्थित कूड़ा निस्तारण प्लान्ट के 42,120 मीट्रिक टन फ्रैश वेस्ट के प्रसंस्करण, निपटान एवं निष्कासन किये जाने के सम्बन्ध में।	3,79,08,000/-	37,90,800/-	19,050+3,429=22,479/-रु0	06 माह

नोट:-जो अनुभवी फर्म/कम्पनी ई-निविदा में भाग लेना चाहते हैं, वह अपना ऑनलाईन पंजीकरण वेबसाईट <https://etender.up.nic.in> पर अनिवार्य रूप से करा ले।

  
नगर स्वास्थ्य अधिकारी  
नगर पालिका परिषद  
मुजफ्फरनगर

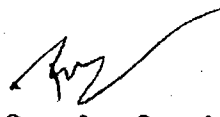
  
अधिशासी अधिकारी  
नगर पालिका परिषद  
मुजफ्फरनगर

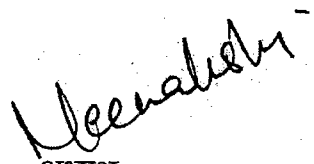
  
अध्यक्ष  
नगरपालिका परिषद  
मुजफ्फरनगर।

नगर स्वास्थ्य अधिकारी/अधिकासी अधिकारी/मा0 अध्यक्ष महोदया,

57

कृपया नगरीय क्षेत्र की सफाई व्यवस्था को दृष्टिगत रखते हुए किदवईनगर स्थित कूड़ा प्लांट पर प्रतिदिन जाने वाले कूड़े को सोलिड वेस्ट सैग्रीगेशन मशीन 500 टन प्रतिदिन क्षमता कूड़ा निस्तारण प्लांट हेतु पालिका द्वारा 15 वे वित्त आयोग से प्राप्त धनराशि के अन्तर्गत व्ययानुमान अंकन-2,38,20,160/-रु0 का प्रस्ताव तैयार कराकर जिलाधिकारी की अध्यक्षता में गठित समिति के समक्ष प्रस्तुत किया गया। माह अगस्त 2023 में मुख्य सचिव महोदय द्वारा विडियो कॉन्फ्रेंसिंग के दौरान निर्देशित किया गया कि नगर पालिका परिषद, मुजफ्फरनगर को कूड़ा निस्तारण किये जाने हेतु ट्रॉमल आदि क्रय कर स्थापित न किये जाये अपितु कूड़ा निस्तारण कार्य को निविदाये आमन्त्रित कर चयनित फर्म द्वारा कराया जाये।

डम्प साईट पर प्रतिदिन लगभग 234 मीट्रिक टन कूड़ा निरन्तर डम्प होने के कारण इसकी मात्रा दिन प्रतिदिन बढ़ रही है। नगरीय क्षेत्र की सफाई व्यवस्था को दृष्टिगत रखते हुए किदवईनगर स्थित कूड़ा प्लांट पर नगरीय क्षेत्र से प्रतिदिन जाने वाले कूड़े का प्रसंस्करण, निपटान एवं निष्कासन किये जाने की नितान्त आवश्यकता है क्योंकि डम्पसाईट पर वर्तमान में जनित कूड़े को डम्प किये जाने के लिये स्थान की कमी पड रही है यदि समय पर कूड़े का निस्तारण प्रारम्भ नहीं किया गया तो वर्तमान में जनित कूड़े को डम्प किये जाने के लिये स्थान रिक्त नहीं रहेगा।

बोर्ड बैठक दिनांक 19.07.2023 के प्रस्ताव संख्या-85 के अन्तर्गत कूड़ा निस्तारण किये जाने हेतु व्ययानुमान अंकन 900/-रुपये प्रति मीट्रिक टन की स्वीकृति बोर्ड द्वारा प्रदान की गयी है। प्रतिदिन जनित कूड़े 234 मीट्रिक टन के अनुसार 06 माह तक एकत्रित कूड़े की मात्रा  $(234 \times 30 \times 6)$  42,120 मीट्रिक टन होगी क्योंकि व्ययानुमान अंकन 900/-रुपये प्रति मीट्रिक टन के अनुसार 42,120 मीट्रिक टन कूड़े के निस्तारण में व्यय अंकन-3,79,08,000/-रु0 होगा। उपरोक्त कुल व्ययानुमान अंकन-3,79,08,000/-रु0 के अनुसार प्रसंस्करण, निपटान एवं निष्कासन 06 माह में किये जाने हेतु ई-निविदा आमन्त्रित की जानी है।

उपरोक्त के क्रम में 42,120 मीट्रिक टन कूड़े के निस्तारण हेतु अंकन-900/-रु0 प्रति मीट्रिक टन की दर से कुल व्ययानुमान अंकन-3,79,08,000/-रु0 के अन्तर्गत प्रसंस्करण, निपटान एवं निष्कासन 06 माह में किये जाने हेतु ई-निविदा आमन्त्रित की जाने की स्वीकृति अपेक्षित है।

उपरोक्त कुल 42,120 मीट्रिक टन कूड़े के निस्तारण हेतु व्ययानुमान अंकन-3,79,08,000/-रु0 की स्वीकृति मा0 अध्यक्ष महोदया द्वारा दिनांक-20.06.2024 को बोर्ड स्वीकृति की प्रत्याशा में प्रदान करते हुए पुनः ई-निविदा आमन्त्रित किये जाने की अनुमति प्रदान की गयी जिसके क्रम में उक्त कार्य कराये जाने हेतु समाचार पत्रों के माध्यम से दिनांक-13.07.2024 को 03:00 बजे तक ई-निविदा आमन्त्रित की गयी जिनको अधिकासी अधिकारी महोदया की स्वीकृति के अनुपालन में खाला गया जिसमें मात्र एक फर्म की निविदा प्राप्त हुई जो निरस्त किये जाने योग्य है।

अतः अवलोकन कर उपरोक्त कार्य हेतु आमन्त्रित निविदाओ को निरस्त कर पुनः अल्पकालीन ई-निविदा आमन्त्रित किये जाने की स्वीकृति प्रदान करना चाहे, साथ ही पत्रावली के दाई ओर संलग्न अल्पकालीन ई-निविदा सूचना के प्रारूप पर हस्ताक्षर करने के साथ-साथ निविदा प्रकाशन हेतु किन्ही दो समाचार पत्रों के नाम अंकित करना चाहे।

*[Signature]*  
23/07/2024

*[Signature]*  
24/7/24  
सफाई एवं खाद्य निरीक्षक  
नगर पालिका परिषद  
मुजफ्फरनगर

*[Signature]*  
24/7/2024  
मुख्य अधिकारी निरीक्षक  
न०पा० परि० मुजफ्फरनगर

*[Signature]*  
24/7/24  
नगर स्वास्थ्य अधिकारी  
नगर पालिका परिषद  
मुजफ्फरनगर

देशिक विज्ञान अकादमी  
के प्रकाशन अर्थात्

*[Signature]*  
29/7/24  
अध्यक्ष  
नगर पालिका परिषद  
मुजफ्फरनगर

*[Signature]*  
10/12/20  
अधिकासी अधिकारी  
नगर पालिका परिषद  
मुजफ्फरनगर

कार्यालय नगरपालिका परिषद, मुजफ्फरनगर

58

743/सा0प्र0/2024-25

369

दिनांक: 30/7/2024

अल्पकालीन ई-निविदा सूचना

ANNEXURE A16

नगर पालिका परिषद, मुजफ्फरनगर द्वारा किदवईनगर स्थित कूडा निस्तारण प्लान्ट पर प्रतिदिन आने वाले फ्रैश वेस्ट के प्रसंस्करण, निपटान एवं निष्कासन अनुभवी फर्म/कम्पनी/ठेकेदार से कार्य कराये जाने हेतु ई-निविदाए दिनांक 16/08/24 को अपरान्ह 3:00 बजे तक आमन्त्रित की जाती है। वेबसाईट <https://etender.up.nic.in> पर निविदा फार्म ऑनलाईन दिनांक 31/07/2024 की सायं 10:00 के बाद से दिनांक 16/08/24 की सायं 3:00 बजे तक डाउनलोड तथा अपलोड किये जा सकते हैं। साथ ही निविदादाता को स्वघोषणा पत्र देना अनिवार्य होगा यह स्वघोषणा पत्र अकन-100/-रु0 के स्टाम्प पेपर पर नोटरी द्वारा सत्यापित होना आवश्यक है। कार्य की धरोहर राशि एफ0डी0आर0/एन0एस0सी0 आदि के रूप में जो अधिशासी अधिकारी नगर पालिका परिषद, मुजफ्फरनगर के नाम बन्धक होगी, तथा निविदा मूल्य (जी0एस0टी0 सम्मिलित करते हुए) का ड्राफ्ट नगर पालिका परिषद, मुजफ्फरनगर के पक्ष में जारी करते हुए निविदा खोले जाने से पूर्व मूल प्रति के रूप में कार्यालय को उपलब्ध कराया जाना अनिवार्य हैं। अन्य विवरण एवं शर्तें किसी भी कार्य दिवस में स्वास्थ्य विभाग कार्यालय में आकर अवलोकन कर सकते हैं। प्राप्त निविदाओं को दिनांक 16/08/2024 को सायं 4:00 बजे अधिशासी अधिकारी के कार्यालय में खोली जायेगी तथा निविदा खोले जाने वाली दिनांक को सार्वजनिक अवकाश एवं विषम स्थिति उत्पन्न होने की दशा में निविदा अगले कार्यदिवस में सायं 4:00 बजे खोली जायेगी। अधिक जानकारी के लिए ऊपर दी गयी वेबसाईट पर लॉगइन कर सकते हैं।

क्र0 सं0	कार्य का नाम	व्ययानुमान की धनराशि मय जी0एस0टी0	10 प्रतिशत धरोहर राशि	निविदा मूल्य 18 प्रतिशत जी0एस0टी0 सहित	कार्य पूर्ण अवधि
1	किदवईनगर स्थित कूडा निस्तारण प्लान्ट के 42,120 मीट्रिक टन फ्रैश वेस्ट के प्रसंस्करण, निपटान एवं निष्कासन किये जाने के सम्बन्ध में।	3,79,08,000/-	37,90,800/-	19,050+3,429=22,479/-रु0	06 माह

नोट:-जो अनुभवी फर्म/कम्पनी ई-निविदा में भाग लेना चाहते हैं, वह अपना ऑनलाईन पंजीकरण वेबसाईट <https://etender.up.nic.in> पर अनिवार्य रूप से करा ले।

नगर स्वास्थ्य अधिकारी  
नगर पालिका परिषद  
मुजफ्फरनगर

अधिशासी अधिकारी  
नगर पालिका परिषद  
मुजफ्फरनगर

अध्यक्ष  
नगरपालिका परिषद  
मुजफ्फरनगर।

3709

ANNEXURE A-1

## कार्यालय नगरपालिका परिषद्, मुजफ्फरनगर

पत्रांक : 1087 सा0प्र0 / 2024-25

दिनांक : 10/01/24

## अल्पकालीन ई-निविदा सूचना

नगर पालिका परिषद्, मुजफ्फरनगर द्वारा किदवईनगर स्थित कूड़ा निस्तारण प्लान्ट पर प्रतिदिन आने वाले फ्रैश वेस्ट के प्रसंस्करण, निपटान एवं निष्कासन अनुभवी फर्म/कम्पनी/ठेकेदार से कार्य कराये जाने हेतु ई-निविदाए दिनांक 20-09-24 को अपराह्न 3:00 बजे तक आमन्त्रित की जाती है। वेबसाईट <https://etender.up.nic.in> पर निविदा फार्म ऑनलाईन दिनांक 11-09-24 की प्रातः 10:00 के बाद से दिनांक 20-09-24 की सायं 3:00 बजे तक डाउनलोड तथा अपलोड किये जा सकते हैं, साथ ही निविदादाता को स्वघोषणा पत्र देना अनिवार्य होगा यह स्वघोषणा पत्र अंकन-100/-रु0 के स्टाम्प पेपर पर नोटरी द्वारा सत्यापित होना आवश्यक है। कार्य की धरोहर राशि एफ0डी0आर0/एन0एस0सी0 आदि के रूप में जो अधिशासी अधिकारी नगर पालिका परिषद्, मुजफ्फरनगर के नाम बन्धक होगी, तथा निविदा मूल्य (जी0एस0टी0 सम्मिलित करते हुए) का ड्राफ्ट नगर पालिका परिषद्, मुजफ्फरनगर के पक्ष में जारी करते हुए निविदा खोले जाने से पूर्व मूल प्रति के रूप में कार्यालय को उपलब्ध कराया जाना अनिवार्य हैं। अन्य विवरण एवं शर्तें किसी भी कार्य दिवस में स्वास्थ्य विभाग कार्यालय में आकर अवलोकन कर सकते हैं। प्राप्त निविदाओं को दिनांक 20-09-24 को सायं 4:00 बजे अधिशासी अधिकारी के कार्यालय में खोली जायेगी तथा निविदा खोले जाने वाली दिनांक को सार्वजनिक अवकाश एवं विषम स्थिति उत्पन्न होने की दशा में निविदा अगले कार्यदिवस में सायं 4:00 बजे खोली जायेगी। अधिक जानकारी के लिए ऊपर दी गयी वेबसाईट पर लॉगइन कर सकते हैं।

क्र0 सं0	कार्य का नाम	व्ययानुमान की धनराशि मय जी0एस0टी0	10 प्रतिशत धरोहर राशि	निविदा मूल्य 18 प्रतिशत जी0एस0टी0 सहित	कार्य पूर्ण अवधि
1	किदवईनगर स्थित कूड़ा निस्तारण प्लान्ट के 42,120 मीट्रिक टन फ्रैश वेस्ट के प्रसंस्करण, निपटान एवं निष्कासन किये जाने के सम्बन्ध में।	3,79,08,000/-	37,90,800/-	19,050+3,429=22,479/-रु0	06 माह

नोट:-जो अनुभवी फर्म/कम्पनी ई-निविदा में भाग लेना चाहते हैं, वह अपना ऑनलाईन पंजीकरण वेबसाईट <https://etender.up.nic.in> पर अनिवार्य रूप से करा ले।

नगर स्वास्थ्य अधिकारी  
नगर पालिका परिषद्  
मुजफ्फरनगर

अधिशासी अधिकारी  
नगर पालिका परिषद्  
मुजफ्फरनगर

अध्यक्ष  
नगरपालिका परिषद्  
मुजफ्फरनगर।